

RENEWABLE ENERGY SOURCES
(MR15)
(PROFESSIONAL ELECTIVES – 5)

MODULE-I

Energy can be classified into several types based on the following criteria:

- Primary and Secondary energy
- Commercial and Noncommercial energy
- Renewable and Non-Renewable energy
- Conventional and Non-conventional energy

- **Primary and Secondary Energy:**

Primary energy sources are those that are either found or stored in nature. Common primary energy sources are coal, oil, natural gas, and biomass (such as wood). Other primary energy sources available include nuclear energy from radioactive substances, thermal energy stored in earth's interior, and potential energy due to earth's gravity.

Primary energy sources are costly converted in industrial utilities into secondary energy sources
Ex: coal, oil or gas converted into steam and electricity. Primary energy can also be used directly. Some energy sources have non-energy uses

Ex: coal or natural gas can be used as a feedstock in fertilizer plants.

- **Commercial Energy and Non Commercial Energy:**

Commercial Energy:

The energy sources that are available in the market for a definite price are known as commercial energy. By far the most important forms of commercial energy are electricity, coal and refined petroleum products. Commercial energy forms the basis of industrial, agricultural, transport and commercial development in the modern world. In the industrialized countries, commercialized fuels are predominant source not only for economic production, but also for many household tasks of general population.

Examples: Electricity, lignite, coal, oil, natural gas etc.

Non-Commercial Energy:

The energy sources that are not available in the commercial market for a price are classified as non-commercial energy. Non-commercial energy sources include fuels such as firewood, cattle dung and agricultural wastes, which are traditionally gathered, and not bought at a price used especially in rural households. These are also called traditional fuels. Non-commercial energy is often ignored in energy accounting.

Example: Firewood, agro waste in rural areas; solar energy for water heating, electricity generation, for drying grain, fish and fruits; animal power for transport, threshing, lifting water for irrigation, crushing sugarcane; wind energy for lifting water and electricity generation.

- **Conventional and Non-Conventional Energy:**

Conventional energy resources are those which are being traditionally used for many decades and were in common use around oil crisis of 1973 are called conventional energy resources, e.g., fossil fuel, nuclear and hydro resources.

Non-conventional energy resources which are considered for large scale use after oil crisis of 1973,

Ex: Solar energy, Bio mass energy, Wind energy etc.

Solar radiation:

The earth receives the solar energy in the form of solar radiation. These radiations comprising of ultra-violet, visible and infrared radiation. The amount of solar radiation that reaches any given location is dependent on several factors like geographic location, time of day, season, land scope and local weather. Because the earth is round, the sun rays strike the earth surface at different angles (ranging from 0° to 90°). When sun rays are vertical, the earth's surface gets maximum possible energy. Most of the part of India receives 4 to 7 kWh of solar radiation per square meter per day. India receives solar energy equivalent more than 5000 trillion kWh per year.

Solar radiation (Direct, diffuse and total solar radiation):

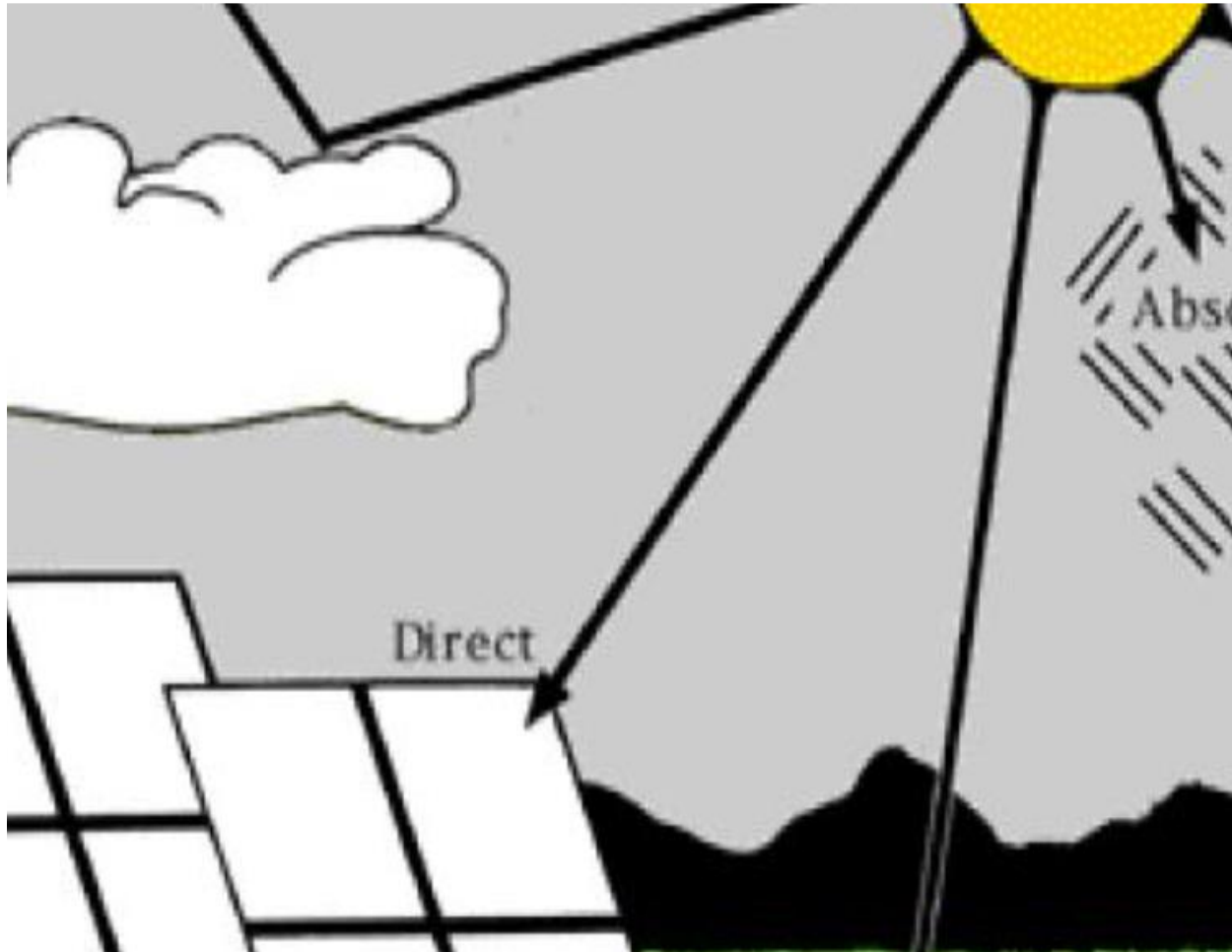

The solar radiation that reaches the surface of the earth without being diffused is called direct beam solar radiation. It is measured by instrument named as pyrheliometer.

As sun light passes through the atmosphere, some part of it is absorbed, scattered and reflected by air molecule, water vapors, clouds, dust and pollutants. This is called diffuse solar radiation. The diffuse solar radiation does not have unique path.

The sum of the direct and diffuse solar radiations is called total radiation or global solar radiation. Pyranometer is used for measuring the total radiation.

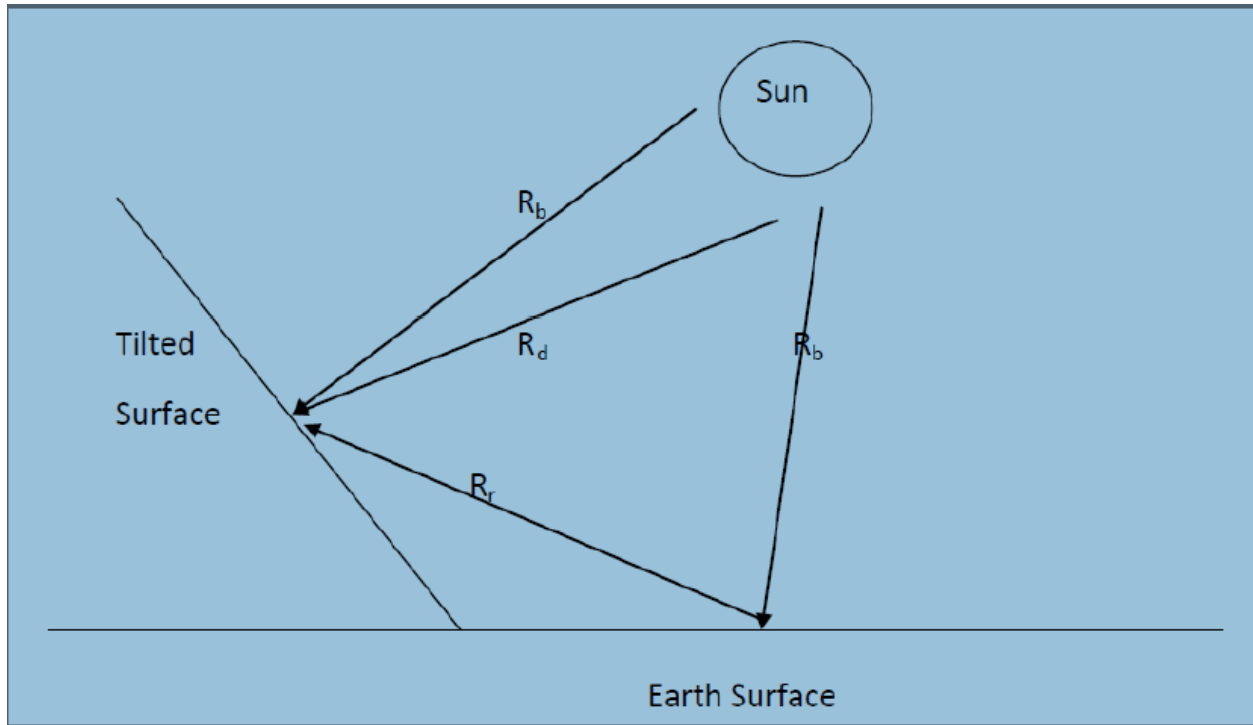

Direct, diffuse and total solar radiation

If,

R_b - Beam Radiation (direct solar radiation)

R_d - Diffuse Radiation (solar radiation after diffusion)

R_r - Reflected radiation (solar radiation after reflection from surface)

R_t - Total solar radiation on tilted surface

Then,

$$R_t = R_b + R_d + R_r$$

Sun – Earth angles

Latitude (ϕ)

The latitude of a location is the angle made by the radial line joining the location to the centre of the earth with the projection of the line on the equatorial plane.

$$-90^\circ \leq \phi \leq +90^\circ$$

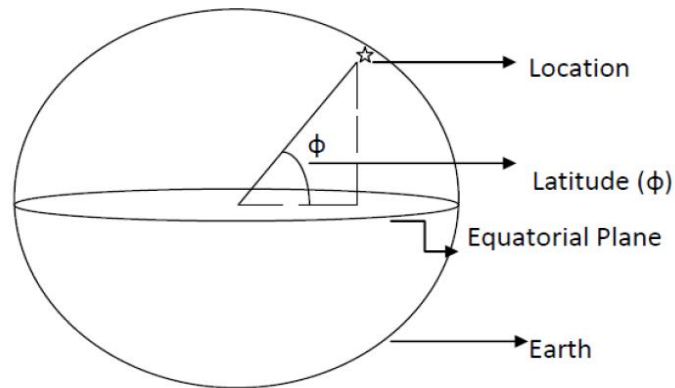

Declination (δ)

The declination angle is the angle made by the line joining the center of the sun and the earth with its projection on equatorial plane.

$$\delta = 23.45 \sin 360 \frac{(284+n)}{365}$$

(Where, n- number of days)

$\delta < 0$ – for winters in northern hemisphere

$\delta > 0$ – for summer in northern hemisphere

Calculate declination angle for March 22 in a non-leap year.

Solution: On March 22, n= 31 (January) + 28 (February) + 22 (22nd march)

n= 81 days

So,

$$\delta = 23.45 \sin 360 \frac{(284+81)}{365} = 0$$

On March 22 and September 22, the declination is zero so these days are called equinoxial day.

Calculate declination angle for March 31 in a leap year.

Solution: On March 22, n= 31 (January) + 29 (February) + 31 (31st march)

n= 91 days

So,

$$\delta = 23.45 \sin 360 \frac{(284+91)}{365} = 4.016^\circ$$

Hour angle (ω)

It is the angle through which the earth must be rotated to bring the meridian of the plane directly under the sun

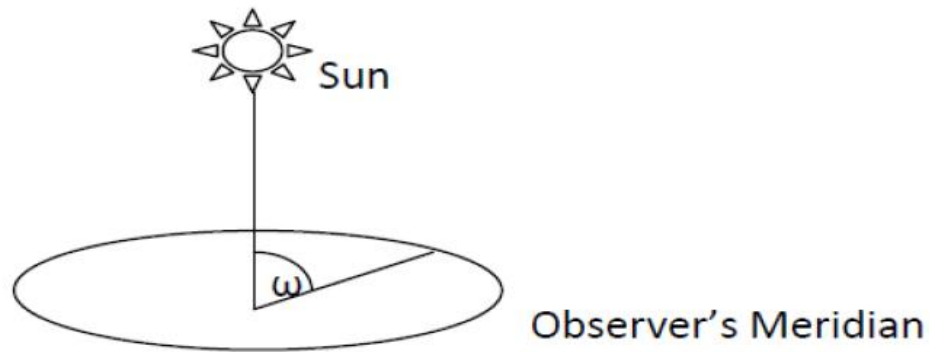

Because it is 24 hours for 360° of rotation, so each one hour correspond to 15°

$$\omega = 15 (ST - 12)$$

Where, ST – solar time

Altitude Angle (α) and Zenith angle (θ_z)

Altitude angle is the angle between the incident sun ray and the projection of sun's rays on the horizontal plane.

Zenith angle is the complementary angle of sun's altitude angle

$$\theta_z = 90^\circ - \alpha$$

zenith angle is the angle between the incident sun ray and the perpendicular line to the horizontal plane.

$$\cos \theta_z = \sin \phi \sin \delta + \cos \phi \cos \delta \cos \omega$$

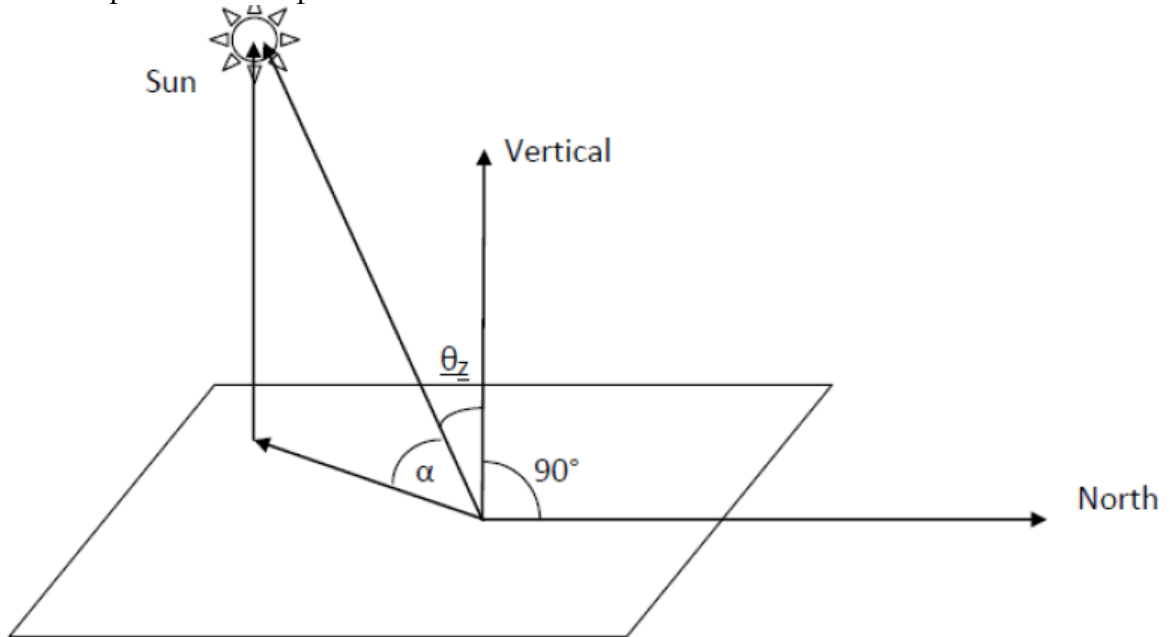

Surface azimuth angle (γ) and solar azimuth angle (γ_s)

Consider a surface with slope “ β ”. Draw an outer normal to this surface and take a projection of normal on horizontal plane.

Surface azimuth angle is the angle between line due south and the projection of normal to the surface on horizontal plane.

Solar azimuth angle is the angle between line due south and the projection of sun rays on horizontal plane.

$$\cos \gamma_s = \frac{\cos \theta_z \cdot \sin \phi - \sin \beta}{\sin \theta_z \cdot \cos \phi}$$

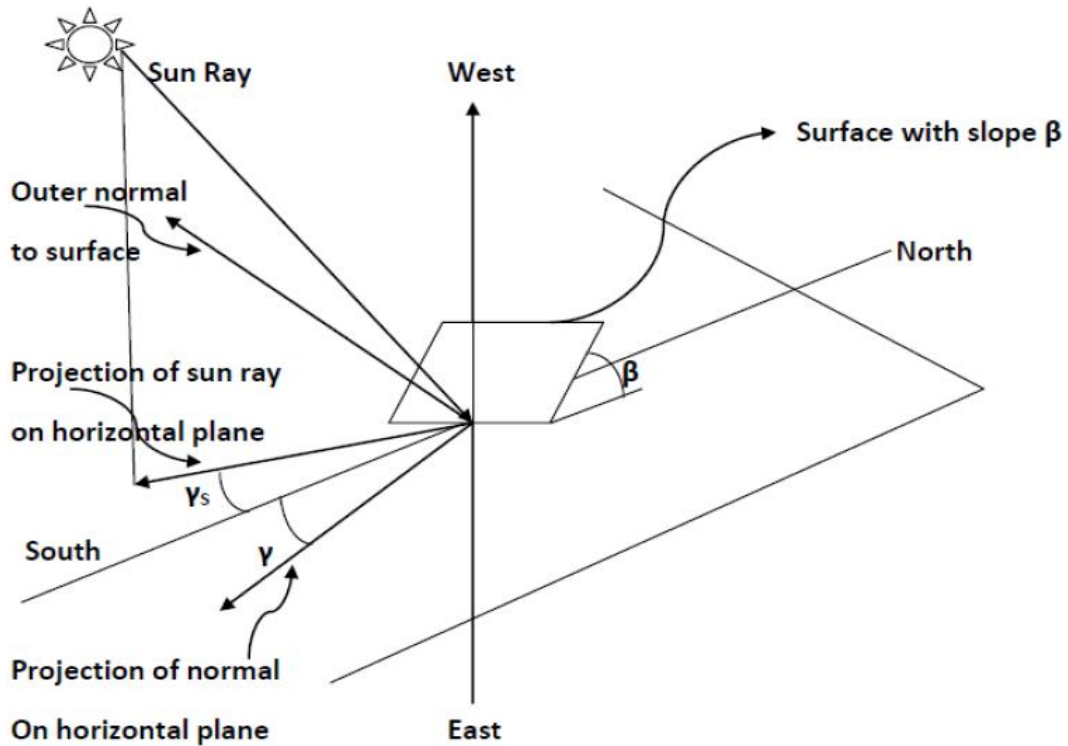

Calculate the sun's altitude and azimuth angle at 9 AM solar time on September 1st at latitude of 23°N .

Solution: $\phi = 23^\circ$, $n = 244$ days

$$\omega = 15(9 - 12) = 45^\circ$$

$$= 7.724^\circ$$

$$\cos \theta_z = \sin(23^\circ) \sin(7.724^\circ) + \cos(23^\circ) \cos(7.724^\circ) \cos(45^\circ)$$

$$\theta_z = 45.87^\circ$$

$$\cos \gamma_s = \frac{\cos 45.87 \cdot \sin 23 - \sin 7.724}{\sin 45.87 \cdot \cos 23}$$

$$\gamma_s = 78.01^\circ$$

MODULE-II

Introduction

The Sun is most prominent source of energy in our system. The source of solar energy is process of thermonuclear fusion in the sun's core. This energy is radiated from sun in all directions and a fraction of this energy is reaches to the earth.

The sun's outer visible layer is called the photosphere and has a temperature of about 6000°C. Above the photosphere there is a transparent layer of gases known as chromospheres. The light emitted by the chromospheres is of short wave length. Finally there is the corona. The corona is the outer part of the sun's atmosphere. In this region, prominence appear. Prominence is immense clouds of glowing gas that erupt from upper chromospheres. The corona can only be seen during total solar eclipse.

Flat plate solar collector

Solar collector absorbs the incident solar radiation and converts it to the useful heat which is use for heating a collector fluid such as water, oil or air.

Flat plate collector are used where temperature below 100°C are required.

The important parts of flat plate collectors:

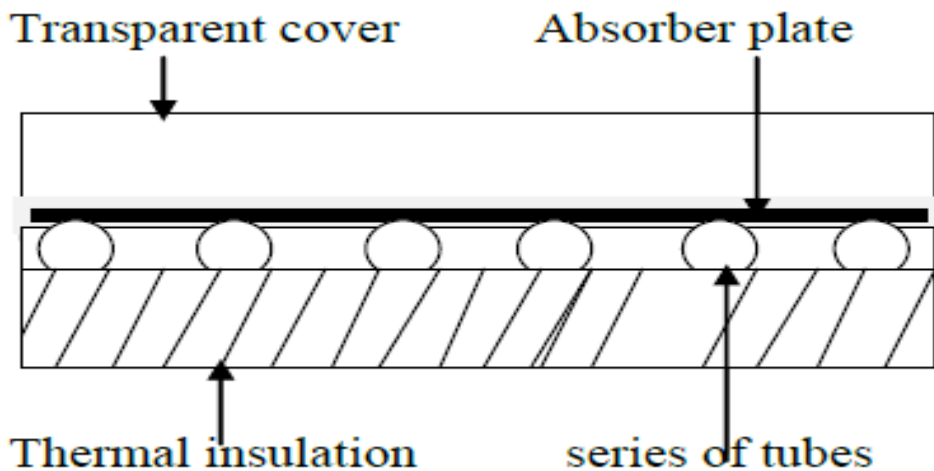

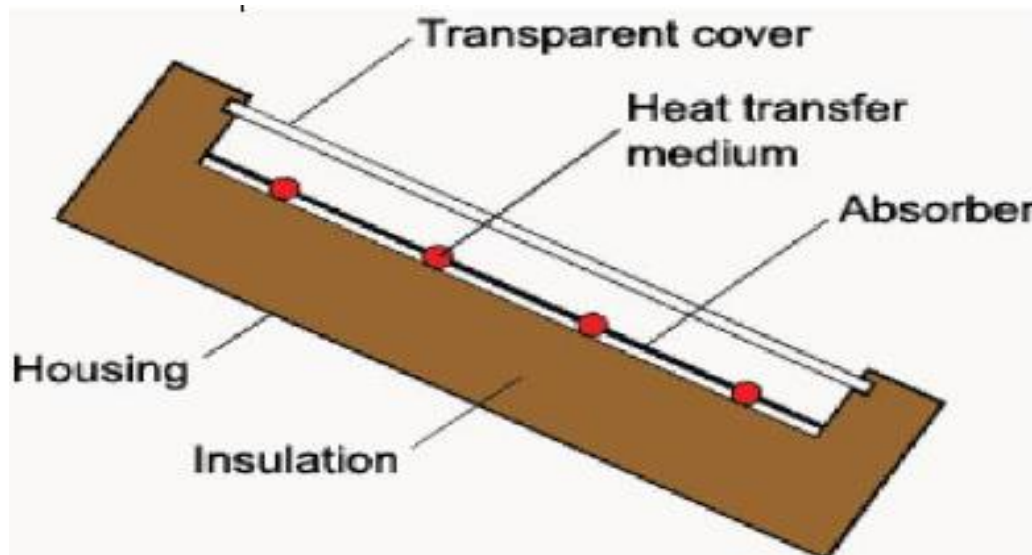

Construction

Transparent Cover:

This allows solar energy to pass through, but reduces the heat loss examples are tempered glass, transparent plastic materials etc

Absorber plate:

Plate is blackened in order to absorb the maximum amount of solar radiations.

The absorber consists of a thin sheet. This sheet is made of conductor material (aluminum, steel, copper etc.) because the metal is a good conductor of heat. Black coating is applied to this conductor / metal plate in order to absorb the maximum amount of solar radiations.

Copper is best material for absorber plate because it has high thermal conductivity, adequate tensile strength and good corrosion resistance.

Series of tubes:

The absorber plate with several parallel tubes is fabricated from copper tube and sheet by soft soldering.

Heat transport fluid (Water):

To remove heat from the absorber, fluid is usually circulated through tubes to transfer heat from the absorber to an insulated water tank.

Thermal insulation:

It is used to provide insulation on the sides and bottom so as to prevent losses and thereby attain high temperatures. Examples of thermal insulations are crown white wool, glass wool, calcium silicate etc.

Working:

When solar radiation passes through the transparent cover and incident on blackened absorber surface of high absorptivity, a large portion of this energy is absorbed by the plate and then transferred to the fluid (Air, Water etc)

Thermal insulation is used to reduce conduction losses and transparent cover is used to reduce convection losses.

Note – when air is used as heat transport fluid, it is flat plate air collector which is used for space heating (solar space heater) and when liquid is used as heat transport fluid, it is flat plate liquid collector which is used for water heating (solar water heater).

Solar flat plate collector type water heating system:

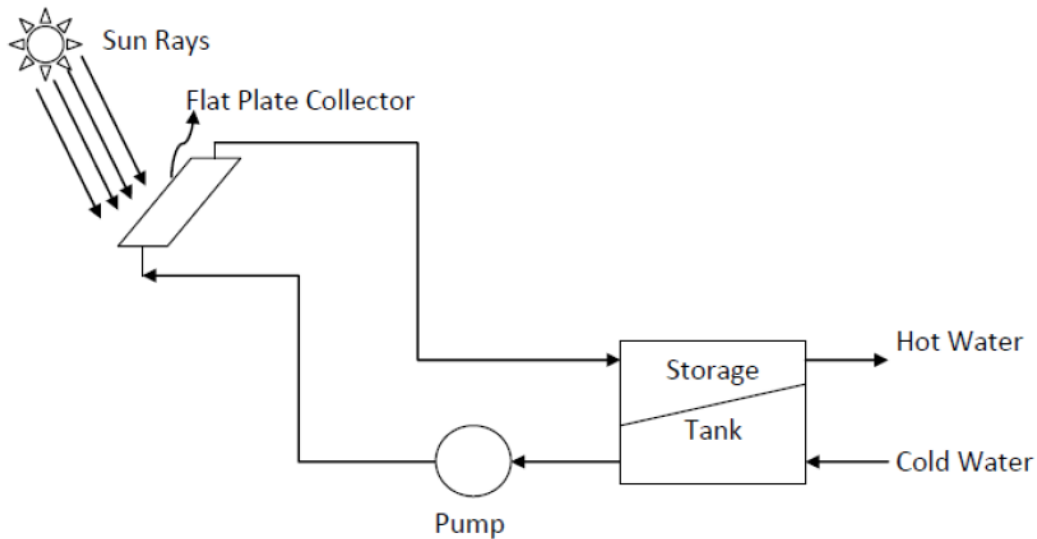

Solar Water Heater

Cold water is pumped to the flat plate collector, collector absorbs the heat by solar radiation and heated water is stored in the tank.

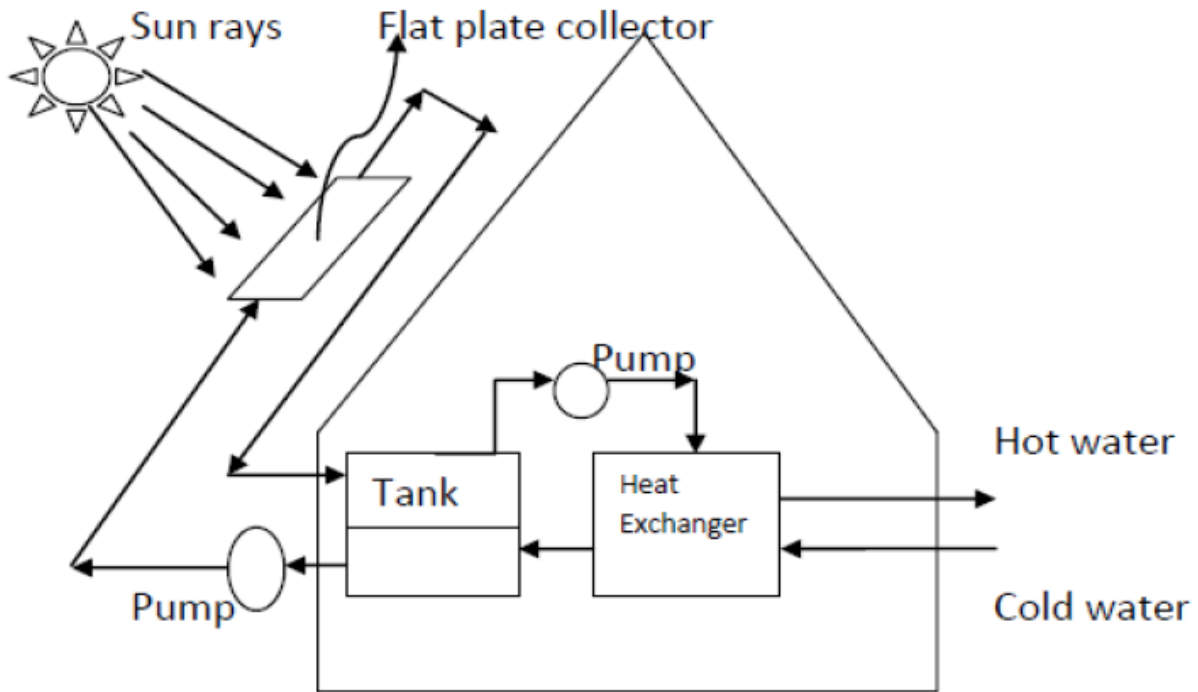

Solar Space Heater

Water is heated by incident solar radiation on flat plate collector. This heated water is collected in a tank.

The energy is transferred to the air circulating in the house by water to air heat exchanger.

Concentrating collectors / focusing collectors (Cylindrical trough solar collector):

Focusing collector has less heat loss so they operate at higher temperature. Flat plate collectors operate on temperature about 100°C in summer and 40°C in winter. So, in order to increase the temperature range of collectors, focusing of collectors are used.

In focusing collectors, a parabolic mirror is used. The sun rays are focused on the focal point of the mirror by reflection from its surface.

A tube is placed along the focal line of the mirror and fluid is circulated through the tube this fluid absorb the heat from reflected solar radiation.

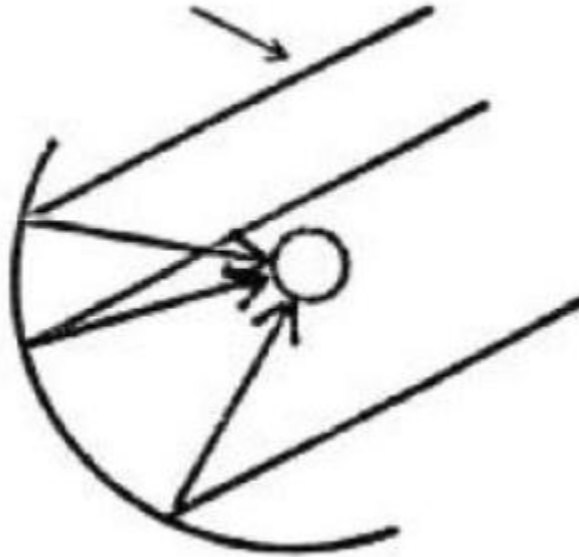

Concentrating type collector

With these collectors, temperature of 200°C - 300°C or above may be obtained. In some mechanism, seasonal tracking of sun is also provided to get the maximum heat from sun light.

The focusing collectors can have two arrangements namely cylindrical parabolic concentrator (100°C < T < 200°C) and parabolic mirror arrays (T > 200°C)

The concentrator increases the intensity of solar radiation by a concentration ratio “C”

$$C = (A_a / A_b)$$

A_a - Aperture area, A_b - Absorber area.

The C value of 20 to 100 can be achieved by a linear concentrator such as parabolic trough concentrator and the C value of 100 to 4000 can be achieved by a point focus concentrator such as parabolic dish.

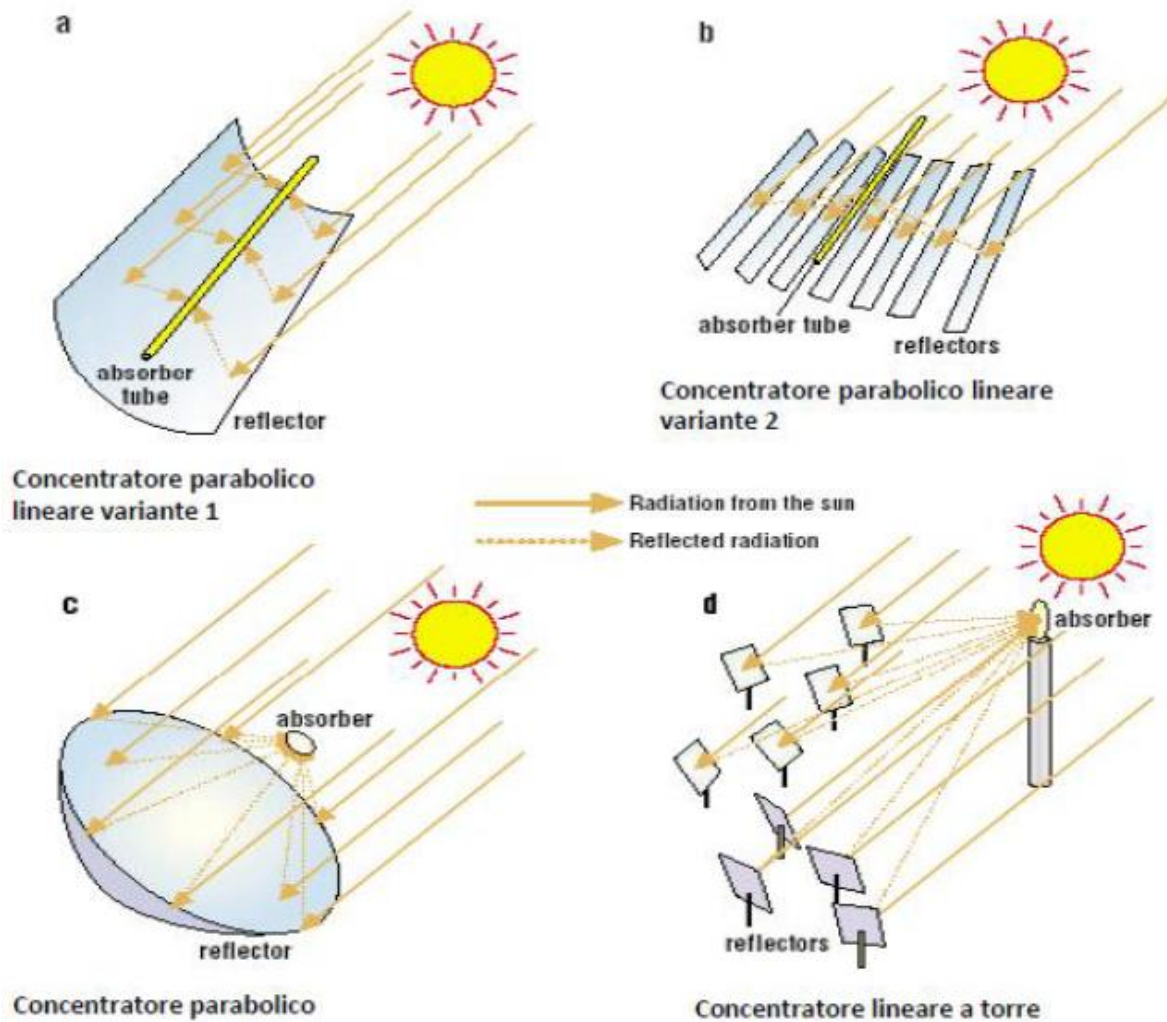

Different types of concentrating / focusing collectors

Materials for concentrators-

Reflector:

Reflector should have high reflectivity. Therefore mirror glass may be used. Glass is the most durable with low iron content so it is a good reflector. Aluminium and silver are also good reflecting surface. Plastics are also used as reflector now days.

Receiving material:

Glass and transparent plastic films are generally used as cover material for receivers. Glass should have low iron content to reduce absorption by it.

Coatings are required to have strong solar absorptivity. Weather resistance, stability at high temperature Examples are black paints, black chrome etc.

Thermal energy storage for solar heating and cooling:

Thermal energy storage is essential for both domestic water and space heating applications. Thermal energy can be stored in well insulated fluids or solids.

There are two ways for thermal energy storage namely sensible heat storage and latent heat storage.

Sensible heat storage:

In sensible heat storage the temperature of the medium changes during charging and discharging of the storage

In this, there is no change in phase. The basic equation for energy storage is given by

$$Q = mc_p\Delta T$$

Where

Q- Total thermal capacity

m- Mass of storage medium

c_p - Specific heat

Heat stored per unit volume (Q/V_s) is given by

$$\frac{mC_p \Delta T}{V_s}$$

Where V_s is the volume of the given storage container

Water is generally used for storing thermal energy at low temperature. Heat transfer oils are used in sensible heat storage system for temperature range 100 - 300°C

Solid materials like rocks, metals, concrete, sand and bricks etc. are also used for thermal storage.

Water is also used as heat transfer fluid for heat flow to and from (but the temperature range is limited)

Latent heat storage:

In latent heat storage, the temperature of the medium remains more or less constant, since it undergoes a phase transformation i.e. the transition from solid to liquid or liquid to vapour.

In a latent heat storage system, the heat is stored in a material when it melts and heat is extracted from material when it freezes example of such materials are paraffin wax, calcium chloride hexahydrate, magnesium nitrate hexahydrate, ice, sodium hydroxide etc.

For latent heat storage charging, phase transition solid- liquid (melting) is most suitable and for storage discharging, liquid- solid (solidification) is most suitable.

The basic equation for energy storage is given by

$$Q = m [C_s(t_m - t_{min}) + h_m + C_L(t_{max} - t_m)] \text{ joule}$$

Where

m- Mass of phase change material (PCM) storage medium

C_s - Specific heat of PCM – solid state (J/KgK)

C_L - Specific heat of PCM – liquid state (J/KgK)

h_m – Specific melting enthalpy of PCM storage medium (J/Kg)

t_{min} - Minimum storage temperature (°C)

t_{max} - maximum storage temperature (°C)

t_m - Melting temperature of PCM storage medium (°C)

The latent heat storage charging process comprises three stages-

First stage is heating of the phase change material in solid state

Second stage is melting of phase change material at constant temperature for pure substance or in the range of temperatures for mixed composition

Third stage involve heating of the molten phase change material to the maximum temperature (t_{max}).

Limitations of Solar thermal energy:

- Low energy density 0.1 to 1 KW/ m²
- Large area is required to collect solar thermal energy
- Direction of rays changes continuously with time
- Energy not available during night and during clouds
- Energy storage is essential
- It has high cost
- Solar central power plants in MW range are not economical

Solar photovoltaic (PV) energy conversion (Photovoltaic effect):

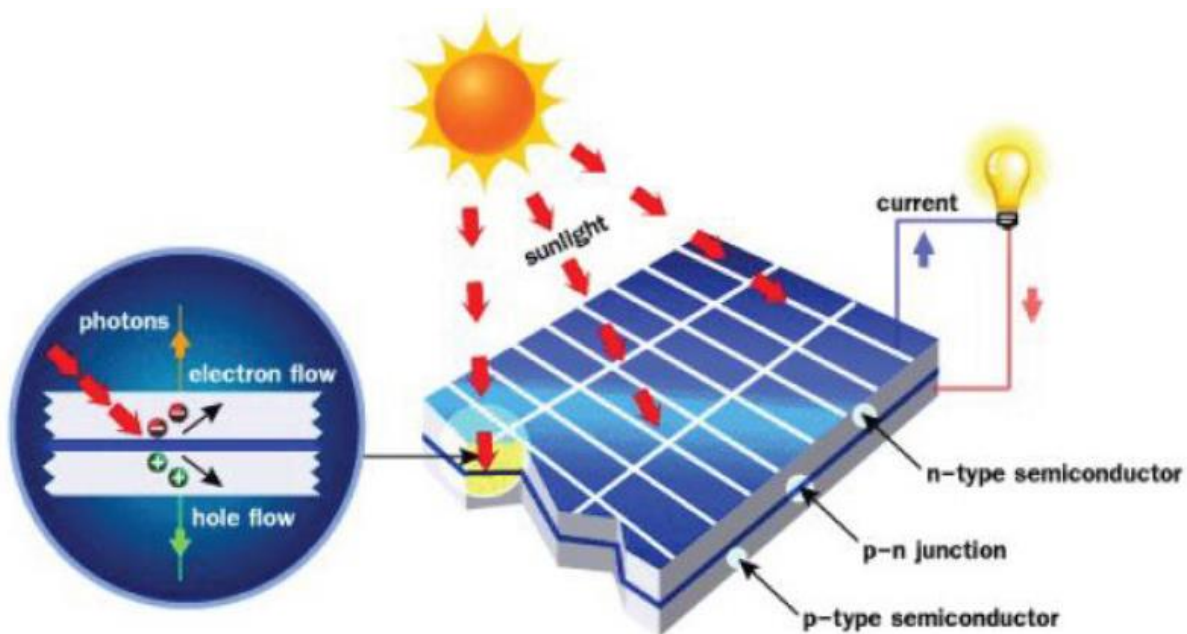

Photovoltaic Effect

A solar cell is nothing but a PN junction diode under light illumination. Sun light can be converted into electricity due to photovoltaic effect. Sun light composed of photons (packets of energy). These photons contain various amount of energy corresponding to different wave lengths of light. When photons strike a solar cell they may be reflected or absorbed or pass through the cell. When solar radiation is absorbed in PN junction diode, electron-hole pairs (EHP) are generated.

Electron hole pair (EHP) generated in depletion layer:

Electrons of EHP will be reaped towards N side because of electric field and holes of EHP will be reaped towards P side because of electric field.

Electron hole pair (EHP) generated in quasi neutral region:

In this region, the electron and holes of EHP will wander around in the region randomly. There is no electric force to guide them in any direction.

Minority carriers of P and N regions:

The minority carrier near the depletion region will also get direction by electric field.

In this way there will be increase of positive charge at P side and increase of negative charge at N side. This buildup of positive and negative charge causes a potential difference to appear across the PN junction due to light falling on it. This generation of photo voltage is known as photovoltaic effect.

Performance analysis of photovoltaic (PV) cell:

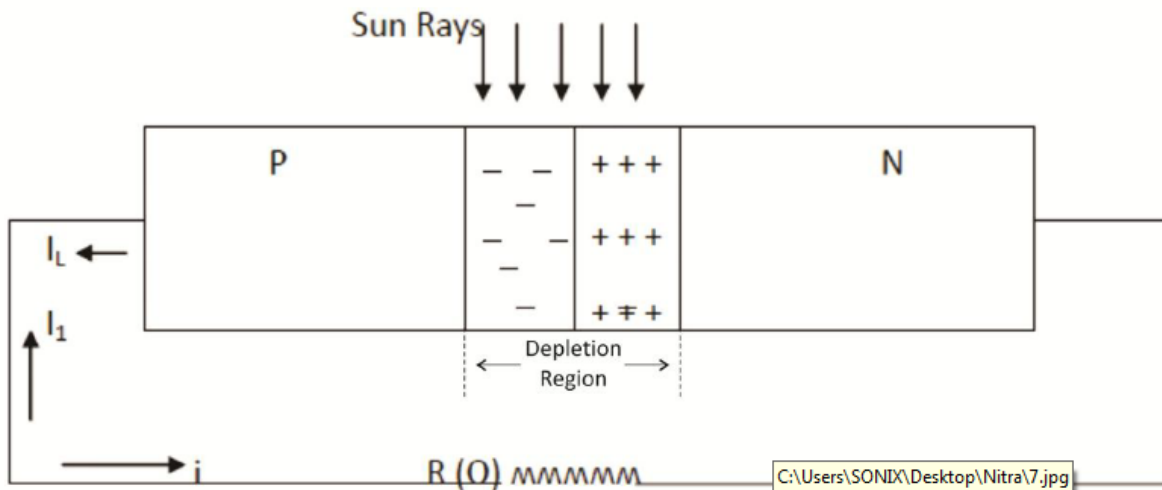

Consider a PN junction with resistive load as shown in figure. When solar cell is illuminated, electron hole pair is generated in the depletion region. This electron hole pair when separated from each other across junction then a current (I_L) flows in external circuit by photovoltaic effect.

This photo current (I_L) produces a voltage drop across resistive load and this voltage will forward bias the PN junction. Forward bias voltage produces forward current (I_1).

So the net current will be, $I = I_L - I_1$.

$$I = I(L) - I(0)\left[\exp\left(\frac{eV}{kT}\right) - 1\right]$$

Short circuit current (I_{sc}):

When $R=0$ and $V = 0$ then $I_1 = 0$

So $I = I_L = I_{sc}$

Open circuit voltage (V_{oc}):

When $R=\infty$ then $I = 0$

$$0 = I(L) - I(0) \left[\exp\left(\frac{ev}{kT}\right) - 1 \right]$$

$$I(L) = I(0) \left[\exp\left(\frac{ev}{kT}\right) - 1 \right]$$

$$V_{oc} = \frac{kT}{e} \left[\ln\left(1 + \frac{I(L)}{I(0)}\right) \right]$$

Power delivered to load:

$$P = V \cdot I$$

$$P = V \cdot \left[I(L) - I(0) \left[\exp\left(\frac{ev}{kT}\right) - 1 \right] \right]$$

for maximum power delivered to load, $\frac{dP}{dV} = 0$

$$\text{By solving, } 1 + \frac{I(L)}{I(0)} = \exp\left(\frac{e \cdot V_m}{kT}\right) \cdot \left[1 + \frac{e \cdot V_m}{kT} \right]$$

Where V_m is the voltage which produces maximum power

Maximum Current:

If we put the value of " $\exp\left(\frac{e \cdot V_m}{kT}\right)$ " from equation 4 to equation 1, we get the maximum value of current (I_m)

Maximum Power:

the maximum power is obtained by multiplying v_m and I_m

$$P_m = V_m \cdot I_m = V_m \frac{e \cdot V_m \cdot (I_L + I_0) / kT}{1 + e \cdot V_m / kT}$$

Efficiency of solar cell:

Conversion efficiency of solar cell is defined as the ratio of output power to incident optical power. For maximum power output,

$$\% \eta = \frac{P_m}{P_{in}} \times 100$$

$$\% \eta = \frac{V_m \cdot I_m}{I \cdot A} \times 100$$

Where, P_m - maximum power(watt), P_{in} - input power(Watt), V_m - maximum voltage(Volt), I_m - maximum current(Amp), I - solar intensity(watt/m²), A - area(m²)

Fill Factor (FF):

It is the ratio of maximum power to the product of V_{oc} and I_{sc}

$$FF = \frac{V_m \cdot I_m}{V_{oc} \cdot I_{sc}}$$

Limitation of solar cell:

There are several factors that limit the efficiency of solar cells, these are:

Photons with energy below the band gap energy, cannot generate electron hole pair so their energy is not converted into useful output. These electrons generate only heat and reduce the electrical efficiency of solar cell

Photons with energy above the band gap energy, only a fraction of energy is used for generating free electrons for conduction. Remaining energy will produce heat and reduce electrical efficiency of solar cells.

When sunlight falls on a solar cell, some part of it is reflected back, some part is absorbed and some part is transmitted, only absorbed solar light is converted into electricity so its efficiency is poor.

MODULE-III

WIND ENERGY

Introduction:

The wind turbine captures the wind's kinetic energy in a rotor consisting of two or more blades mechanically coupled to an electrical generator. The turbine is mounted on a tall tower to enhance the energy capture. Numerous wind turbines are installed at one site to build a wind farm of the desired power generation capacity. Obviously, sites with steady high wind produce more energy over the year. Two distinctly different configurations are available for turbine design, the horizontal-axis configuration (Figure 3.1) and the vertical-axis configuration. The horizontal-axis machine has been the standard in Denmark from the beginning of the wind power industry. Therefore, it is often called the Danish wind turbine. The vertical-axis machine has the shape of an egg beater and is often called the Darrieus rotor after its inventor. It has been used in the past because of its specific structural advantage. However, most modern wind turbines use a horizontal axis design. Except for the rotor, most other components are the same in both designs, with some differences in their placements.

SPEED AND POWER RELATIONS

The kinetic energy in air of mass m moving with speed V is given by the following in joules:

$$\text{kinetic energy} = \frac{1}{2}mV^2$$

The power in moving air is the flow rate of kinetic energy per second in watts:

$$\text{power} = \frac{1}{2}(\text{mass flow per second})V^2$$

If

P = mechanical power in the moving air (watts), ρ = air density (kg/m^3),

A = area swept by the rotor blades (m^2), and V = velocity of the air (m/sec),

Then the volumetric flow rate is AV , the mass flow rate of the air in kilograms per second is ρAV , and the mechanical power coming in the upstream wind is given by the following in watts:

$$P = \frac{1}{2}(\rho AV)V^2 = \frac{1}{2}\rho AV^3$$

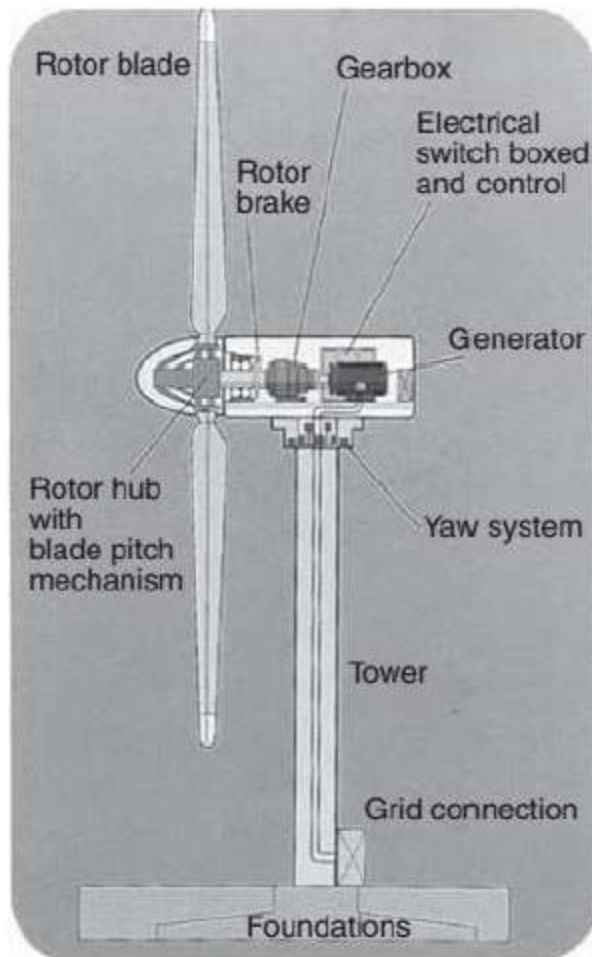

Horizontal-axis wind turbine showing major components.

Two potential wind sites are compared in terms of the specific wind power expressed in watts per square meter of area swept by the rotating blades. It is also referred to as the power density of the site, and is given by the following expression in watts per square meter of the rotor-swept area:

$$\text{specific power of the site} = \frac{1}{2} \rho V^3$$

This is the power in the upstream wind. It varies linearly with the density of the air sweeping the blades and with the cube of the wind speed. The blades cannot extract all of the upstream wind power, as some power is left in the downstream air that continues to move with reduced speed.

POWER EXTRACTED FROM THE WIND

The actual power extracted by the rotor blades is the difference between the upstream and downstream wind powers. Using Equation 3.2, this is given by the following equation in units of watts:

$$P_o = \frac{1}{2} (\text{mass flow per second}) \{V^2 - V_o^2\}$$

Where

P_o = mechanical power extracted by the rotor, i.e., the turbine output power, V = upstream wind velocity at the entrance of the rotor blades, and V_o = downstream wind velocity at the exit of the rotor blades.

Let us leave the aerodynamics of the blades to the many excellent books available on the subject, and take a macroscopic view of the airflow around the blades. Macroscopically, the air velocity is discontinuous from V to V_o at the “plane” of the rotor blades, with an “average” of $(V + V_o)$. Multiplying the air density by the average velocity, therefore, gives the mass flow rate of air through the rotating blades, which is as follows:

$$\text{mass flow rate} = \rho A \frac{V + V_o}{2}$$

The mechanical power extracted by the rotor, which drives the electrical generator, is therefore:

$$P_o = \frac{1}{2} \left[\rho A \frac{(V + V_o)}{2} \right] (V^2 - V_o^2)$$

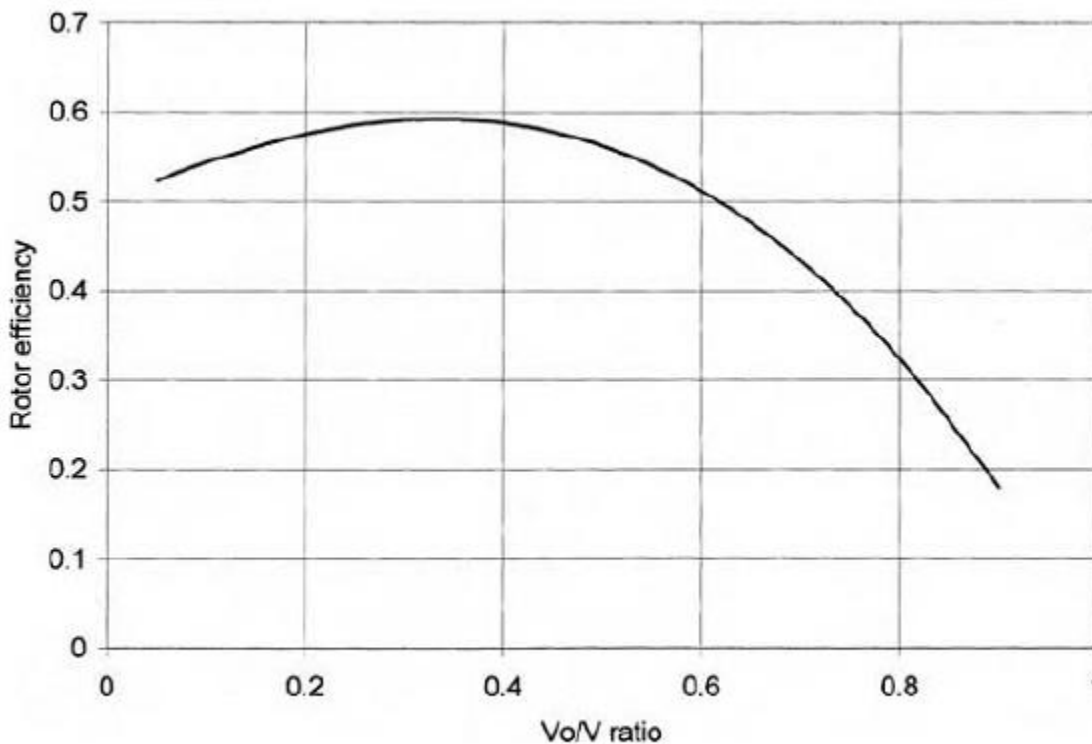

Rotor efficiency vs. V_o/V ratio has a single maximum.

The preceding expression is algebraically rearranged in the following form:

$$P_o = \frac{1}{2} \rho A V^3 \frac{\left(1 + \frac{V_o}{V}\right) \left[1 - \left(\frac{V_o}{V}\right)^2\right]}{2}$$

The power extracted by the blades is customarily expressed as a fraction of the upstream wind power in watts as follows:

$$P_o = \frac{1}{2} \rho A V^3 C_p$$

Where

$$C_p = \frac{\left(1 + \frac{V_o}{V}\right) \left[1 - \left(\frac{V_o}{V}\right)^2\right]}{2}$$

Comparing Equation 3 and Equation 9, we can say that C_p is the fraction of the upstream wind power that is extracted by the rotor blades and fed to the electrical generator. The remaining power is dissipated in the downstream wind. The factor C_p is called the power coefficient of the rotor or the rotor efficiency.

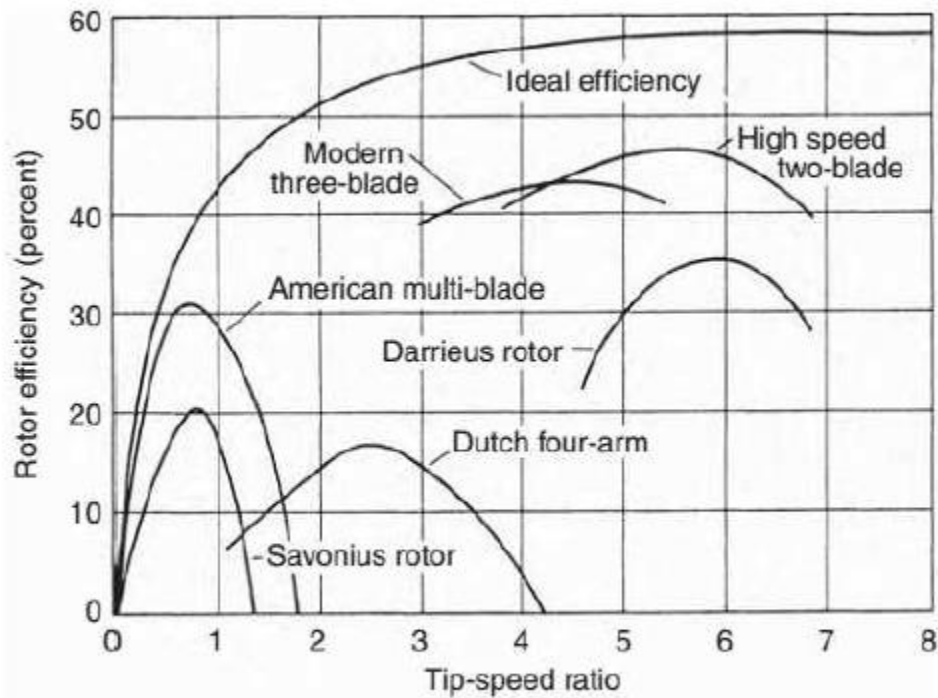

Rotor efficiency vs. V_o/V ratio for rotors with different numbers of blades.

WIND SPEED DISTRIBUTION

Having a cubic relation with power, wind speed is the most critical data needed to appraise the power potential of a candidate site. The wind is never steady at any site. It is influenced by the weather system, the local land terrain, and its height above the ground surface. Wind speed varies by the minute, hour, day, season, and even by the year. Therefore, the annual mean speed needs to be averaged over 10 yr or more. Such a longterm average gives a greater confidence in assessing the energy-capture potential of a site. However, long-term measurements are expensive and most projects cannot wait that long. In such situations, the short-term data, for example, over 1 yr, is compared with long-term data from a nearby site to predict the long-term annual wind speed at the site under consideration. This is known as the measure, correlate, and predict (mcp) technique. Because wind is driven by the sun and the seasons, the wind pattern generally repeats over a period of 1 yr. The wind site is usually described by the speed data averaged over calendar months. Sometimes, the monthly data is aggregated over the year for brevity in reporting the overall “windiness” of various sites. Wind speed variations over the period can be described by a probability distribution function.

WIND SPEED PREDICTION

Because the available wind energy at any time depends on the wind speed at that time, which is a random variable, knowing the average annual energy potential of a site is one thing and the ability to accurately predict when the wind will blow is quite another thing. For the wind farm operator, this poses difficulties in system scheduling and energy dispatching as the schedule of wind power availability is not known in advance. However, a reliable forecast of wind speed several hours in advance can give the following benefits:

- Generating schedule can efficiently accommodate wind generation in a timely manner.
- Allows the grid-connected wind farm to commit to power purchase contracts in advance for a better price
- Allows investors to proceed with new wind farms and avoid the penalties they must pay if they do not meet their hourly generation targets.

Therefore, development of short-term wind-speed-forecasting tools helps wind energy producers. NWTC researchers work in cooperation with the National Oceanic and Atmospheric Administration (NOAA) to validate the nation’s wind resource maps and develop methods of short-term (1 to 4 h) wind forecasting. Previously have also proposed a new technique for forecasting wind speed and power output up to several hours in advance. Their technique is based on cross-correlation at neighboring sites and artificial neural networks and is claimed to significantly improve forecasting accuracy compared to the persistence-forecasting model.

Wind Power System

SYSTEM COMPONENTS

The wind power system comprises one or more wind turbine units operating electrically in parallel. Each turbine is made of the following basic components:

- Tower structure
- Rotor with two or three blades attached to the hub
- Shaft with mechanical gear
- Electrical generator
- Yaw mechanism, such as the tail vane
- Sensors and control

Because of the large moment of inertia of the rotor, design challenges include starting, speed control during the power-producing operation, and stopping the turbine when required. The eddy current or another type of brake is used to halt the turbine when needed for emergency or for routine maintenance.

In a modern wind farm, each turbine must have its own control system to provide operational and safety functions from a remote location. It also must have one or more of the following additional components:

- Anemometers, which measure the wind speed and transmit the data to the controller.
- Numerous sensors to monitor and regulate various mechanical and electrical parameters. A 1-MW turbine may have several hundred sensors.
- Stall controller, which starts the machine at set wind speeds of 8 to 15 mph and shuts off at 50 to 70 mph to protect the blades from overstressing and the generator from overheating.
- Power electronics to convert and condition power to the required standards.
- Control electronics, usually incorporating a computer.
- Battery for improving load availability in a stand-alone plant.
- Transmission link for connecting the plant to the area grid.

The following are commonly used terms and terminology in the wind power industry:

Low-speed shaft: The rotor turns the low-speed shaft at 30 to 60 rotations per minute (rpm).

High-speed shaft: It drives the generator via a speed step-up gear.

Brake: A disc brake, which stops the rotor in emergencies. It can be applied mechanically, electrically, or hydraulically.

Gearbox: Gears connect the low-speed shaft to the high-speed shaft and increase the turbine speed from 30 to 60 rpm to the 1200 to 1800 rpm required by most generators to produce electricity in an efficient manner.

Because the gearbox is a costly and heavy part, design engineers are exploring slow speed, direct-drive generators that need no gearbox.

Generator: It is usually an off-the-shelf induction generator that produces 50- or 60-Hz AC power.

Nacelle: The rotor attaches to the nacelle, which sits atop the tower and includes a gearbox, low- and high-speed shafts, generator, controller, and a brake. A cover protects the components inside the nacelle. Some nacelles are large enough for technicians to stand inside while working.

Pitch: Blades are turned, or pitched, out of the wind to keep the rotor from turning in winds that have speeds too high or too low to produce electricity.

Upwind and downwind: The upwind turbine operates facing into the wind in front of the tower, whereas the downwind runs facing away from the wind after the tower.

Vane: It measures the wind direction and communicates with the yaw drive to orient the turbine properly with respect to the wind.

Yaw drive: It keeps the upwind turbine facing into the wind as the wind direction changes. A yaw motor powers the yaw drive. Downwind turbines do not require a yaw drive, as the wind blows the rotor downwind. The design and operating features of various system components are described in the following subsections.



1. Nacelle
2. Heat Exchanger
3. Offshore Container
4. Small Gantry Crane
5. Oil Cooler
6. Control Pane
7. Generator
8. Impact Noise Reduction
9. Hydraulic Parking Brake
10. Main Frame
11. Swiveling Crane
12. Gearbox
13. Rotor Lock
14. Rotor Shaft
15. Yaw Drive
16. Rotor Hub
17. Pitch Drive
18. Nose Cone

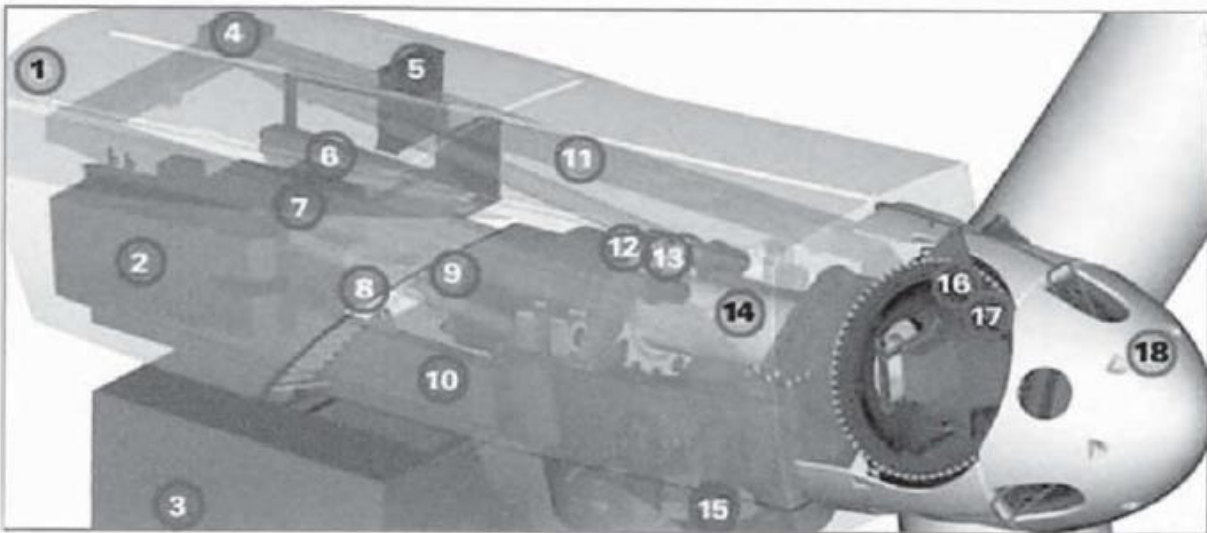

Nacelle details of a 3.6-MW/104-m-diameter wind turbine. (From GE Wind Energy. With permission.)

TOWER

The wind tower supports the rotor and the nacelle containing the mechanical gear, the electrical generator, the yaw mechanism, and the stall control. Figure depicts the component details and layout in a large nacelle, and Figure shows the installation on the tower. The height of the tower in the past has been in the 20 to 50 m range. For medium and large-sized turbines, the tower height is approximately equal to the rotor diameter, as seen in the dimension drawing of a 600-kW wind turbine (Figure 4.4). Small turbines are generally mounted on the tower a few rotor diameters high. Otherwise, they would suffer fatigue due to the poor wind speed found near the ground surface. Figure 4.5 shows tower heights of various-sized wind turbines relative to some known structures. Both steel and concrete towers are available and are being used. The construction can be tubular or lattice. Towers must be at least 25 to 30 m high to avoid turbulence caused by trees and buildings. Utility-scale towers are typically twice as high to take advantage of the swifter winds at those heights.

The main issue in the tower design is the structural dynamics. The tower vibration and the resulting fatigue cycles under wind speed fluctuation are avoided by the design. This requires careful avoidance of all resonance frequencies of the tower, the rotor, and the nacelle from the wind fluctuation frequencies. Sufficient margin must be maintained between the two sets of frequencies in all vibrating modes.

The resonance frequencies of the structure are determined by complete modal analyses, leading to the eigenvectors and Eigen values of complex matrix equations representing the motion of the structural elements. The wind fluctuation frequencies are found from the measurements at the site under consideration. Experience on a similar nearby site can bridge the gap in the required information.

Big cranes are generally required to install wind towers. Gradually increasing tower height, however, is bringing a new dimension in the installation. Large rotors add to the transportation problem as well. Tillable towers to nacelle and rotors moving upwards along with the tower are among some of the newer developments in wind tower installation. The offshore installation comes with its own challenge that must be met.

TURBINE

Wind turbines are manufactured in sizes ranging from a few kW for stand-alone remote applications to a few MW each for utility-scale power generation. The turbine size has been steadily increasing. The average size of the turbine installed worldwide in 2002 was over 1 MW. By the end of 2003, about 1200 1.5-MW turbines made by GE Wind Energy alone were installed and in operation. Today, even larger machines are being routinely installed on a large commercial scale, such as GE's new 3.6-MW turbines for offshore wind farms both in Europe and in the U.S. It offers lighter variable-speed, pitch controlled blades on a softer support structure, resulting in a cost-effective foundation. Its rated wind speed is 14 m/sec with cut in speed at 3.5 m/sec and the cutout at 25 m/sec. The blade diameter is 104 m with hub height 100 m on land and 75 m offshore.

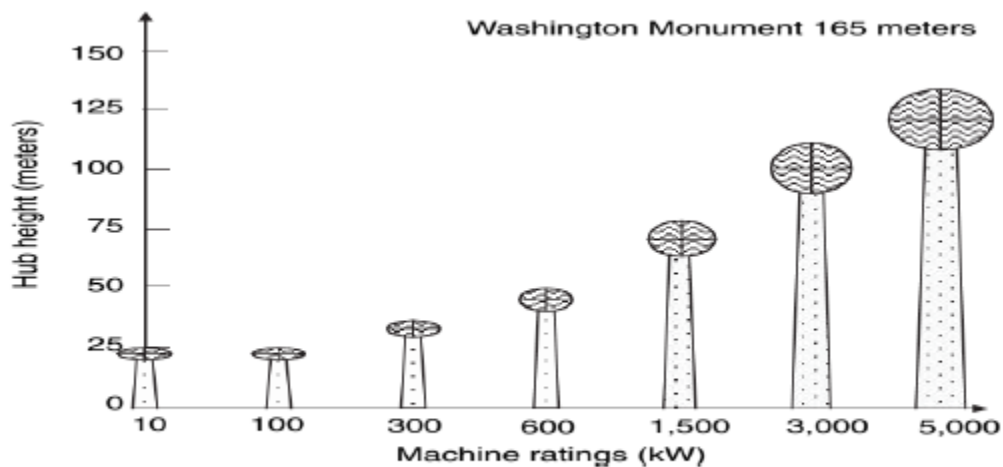

Tower heights of various capacity wind turbines.

In August 2002, Enercon's 4.5-MW wind turbine prototype was installed near Magdeburgh in eastern Germany. It has a 113-m rotor diameter, 124-m hub height, and an egg-shaped nacelle. Its reinforced concrete tower diameter is 12 m at the base, tapering to 4 m at the top. Today, even 5-MW machines are being installed in large offshore wind farms. The mass of a 5-MW turbine can vary from 150 to 300 t in nacelle and 70 to 100 t in the rotor blades, depending on the manufacturing technologies adopted at the time of design. The most modern designs would naturally be on the lighter side of the range. Turbine procurement requires detailed specifications, which are often tailored from the manufacturers' specifications. The leading manufacturers of wind turbines in the world are listed in Table 4.1, with Denmark's Vestas leading with 22% of the world's market share. The major suppliers in the U.S. are GE Wind (52%), Vestas (21%), Mitsubishi (12%), NEG Micon (10%), and Gamesha (3%).

BLADES

Modern wind turbines have two or three blades, which are carefully constructed airfoils that utilize aerodynamic principles to capture as much power as possible. The airfoil design uses a longer

upper-side surface whereas the bottom surface remains somewhat uniform. By the Bernoulli principle, a “lift” is created on the airfoil by the pressure difference in the wind flowing over the top and bottom surfaces of the foil. This aerodynamic lift force flies the plane high, but rotates the wind turbine blades about the hub. In addition to the lift force on the blades, a drag force is created, which acts perpendicular to the blades, impeding the lift effect and slowing the rotor down. The design objective is to get the highest lift-to-drag ratio that can be varied along the length of the blade to optimize the turbine’s power output at various speeds.

The rotor blades are the foremost visible part of the wind turbine, and represent the forefront of aerodynamic engineering. The steady mechanical stress due to centrifugal forces and fatigue under continuous vibrations make the blade design the weakest mechanical link in the system. Extensive design effort is needed to avoid premature fatigue failure of the blades. A swift increase in turbine size has been recently made possible by the rapid progress in rotor blade technology, including emergence of the carbon- and glass-fiber-based epoxy composites. The turbine blades are made of high density wood or glass fiber and epoxy composites. The high pitch angle used for stall control also produces a high force. The resulting load on the blade can cause a high level of vibration and fatigue, possibly leading to a mechanical failure. Regardless of the fixed- or variable-speed design, the engineer must deal with the stall forces. Researchers are moving from the 2-D to 3-D stress analyses to better understand and design for such forces. As a result, the blade design is continually changing, particularly at the blade root where the loading is maximum due to the cantilever effect. The aerodynamic design of the blade is important, as it determines the energy capture potential. The large and small machine blades have significantly different design philosophies. The small machine sitting on a tower relatively taller than the blade diameter, and generally unattended, requires a low-maintenance design. On the other hand, a large machine tends to optimize aerodynamic performance for the maximum possible energy capture. In either case, the blade cost is generally kept below 10% of the total installed cost.

SPEED CONTROL

The wind turbine technology has changed significantly in the last 25 yr. 1 large wind turbines being installed today tend to be of variable-speed design, incorporating pitch control and power electronics. Small machines, on the other hand, must have simple, low cost power and speed control. The speed control methods fall into the following categories:

No speed control whatsoever: In this method, the turbine, the electrical generator, and the entire system are designed to withstand the extreme speed under gusty winds. Yaw and tilt control: The yaw control continuously orients the rotor in the direction of the wind. It can be as simple as the tail vane or more complex on modern towers. Theoretical considerations dictate free yaw as much as possible. However, rotating blades with large moments of inertia produce high gyroscopic torque during yaw, often resulting in loud noise. A rapid yaw may generate noise exceeding the local ordinance limit. Hence, a controlled yaw is often required and used, in which the rotor axis is shifted out of the wind direction when the wind speed exceeds the design limit.

Pitch control: This changes the pitch of the blade with changing wind speed to regulate the rotor speed. Large-scale power generation is moving towards variable-speed rotors with power electronics incorporating a pitch control.

Stall control: Yaw and tilt control gradually shifts the rotor axis in and out of the wind direction. But, in gusty winds above a certain speed, blades are shifted (profiled) into a position such that they stall and do not produce a lift force. At stall, the wind flow ceases to be smooth around the blade contour, but separates before reaching the trailing edge.

This always happens at a high pitch angle. The blades experience a high drag, thus lowering the rotor power output. This way, the blades are kept under the allowable speed limit in gusty winds. This not only protects the blades from mechanical overstress, but also protects the electrical generator from overloading and overheating. Once stalled, the turbine has to be restarted after the gust has subsided.

Advantages of Fixed- and Variable-Speed Systems

Fixed-Speed System

Simple and inexpensive electrical system
Fewer parts, hence, higher reliability
Lower probability of excitation of mechanical resonance of the structure
No frequency conversion, hence, no current harmonics present in the electrical system
Lower capital cost

Variable-Speed System

Higher rotor efficiency, hence, higher energy capture per year
Low transient torque
Fewer gear steps, hence, inexpensive gear box
Mechanical damping system not needed; the electrical system could provide damping if required
No synchronization problems
Stiff electrical controls can reduce system voltage sags

HORIZONTAL VS. VERTICAL AXIS

In the horizontal-axis Danish machine, considered to be classical, the axis of blade rotation is horizontal with respect to the ground and parallel to the wind stream. Most wind turbines are built today with the horizontal-axis design, which offers a cost-effective turbine construction, installation, and control by varying the blade pitch. The vertical-axis Darrieus machine has different advantages. First of all, it is Omni directional and requires no yaw mechanism to continuously orient itself toward the wind direction. Secondly, its vertical drive shaft simplifies the installation of the gearbox and the electrical generator on the ground, making the structure much simpler. On the negative side, it normally requires guy wires attached to the top for support. This could limit its applications, particularly at offshore sites. Overall, the vertical-axis machine has not been widely used, primarily because its output power cannot be easily controlled in high winds simply by changing the blade pitch. With modern low-cost variable-speed power electronics emerging in the wind power industry, the Darrieus configuration may revive, particularly for large-capacity applications.

The Darrieus has structural advantages compared to a horizontal-axis turbine because it is balanced. The blades only “see” the maximum lift torque twice per revolution. Seeing maximum torque on one blade once per revolution excites many natural frequencies, causing excessive vibrations. Also a vertical-axis wind turbine configuration is set on the ground. Therefore, it is unable to effectively use higher wind speeds using a higher tower, as there is no tower here.

MODULE-IV

Geothermal Energy:

Deep inside the Earth, at depths near 150 kilometers, the temperature and pressure is sufficient to melt rock into magma. As it becomes less dense, the magma begins to flow toward the surface. Once it breaks through the crust it is referred to as lava. Lava is extremely hot; up to 1,250 °C. Average lava temperatures are about 750°C. A normal household oven only reaches temperatures near 260°C (500°F).

The rock located just above the magma is also very hot but remains solid. What if we could harness this thermal energy and use it to generate electricity or heat homes and businesses? We would have a domestic, clean, and nearly inexhaustible energy supply. Geothermal energy is one of the components of the National Energy Policy: “Reliable, Affordable, and Environmentally Sound Energy for America’s Future”, (pg. 6-5). Our ancient ancestors knew about this free and reliable energy. They bathed and prepared food in hot springs and many cultures considered geysers and other surface geothermal features as sacred places. Today, due to the explorations and calculations of many scientists and engineers, we’ve realized that only 1% of the geothermal energy contained in the uppermost ten kilometers of the Earth’s crust is 500 times that contained in all the oil and gas resources of the world! The next step is designing technology that can harness this immense, renewable, and low to no - emission energy reservoir. Geothermal energy can be usefully extracted from four different types of geologic formations. These include hydrothermal, geopressurized, hot dry rock, and magma. Hydrothermal reservoirs have been the most common source of geothermal energy production worldwide. They contain hot water and/or steam trapped in fractured or porous rock formations by a layer of impermeable rock on top. Hydrothermal fluids can be used directly to heat buildings, greenhouses, and swimming pools, or they can be used to produce steam for electrical power generation. These power plants typically operate with fluid temperatures greater than 130o C. Geopressurized resources are from formations where moderately high temperature brines are trapped in a permeable layer of rock under high pressures. These brines are found deeper underground than hydrothermal fluids and have high concentrations of salt, minerals, and dissolved methane gas. In addition to producing steam for electrical power generation, minerals can be extracted from brines and used as supplementary revenue for a power plant. This process is known as coproduction. Hot dry rock reservoirs are generally hot impermeable rocks at depths shallow enough to be accessible (Less than 3000 m). Although hot dry rock resources are virtually unlimited in magnitude around the world, only those at shallow depths are currently economical. To extract heat from such formations, the rock must be fractured and a fluid circulation system developed. This is known as an enhanced geothermal system (EGS). The water is then heated by way of conduction as it passes through the fractures in the rock, thus becoming a hydrothermal fluid. The final source of geothermal energy is magma, which is partially molten rock. Molten rock is the largest global geothermal resource and is found at depths below 3-10km. Its great depth and high temperature (between 700°C and 1200°C) make the resource difficult to access and harness. Thus, technology to use magma resources is not well developed. Geothermal power is already an important energy resource for our nation and the world. Hydrothermal plants in the western states now provide about 2,500 megawatts of constant, reliable electricity, which meets the residential power needs for a city of 6 million people. Over 8,000 megawatts are currently being produced worldwide. A variety of industries, including food processing, aquaculture farming, lumber drying, and greenhouse operations, now benefit from direct geothermal heating. The alligators in the following picture are grown in geothermally heated water in Idaho. Hydrothermal systems also provide district heating. District systems distribute hydrothermal fluid from one or more geothermal wells through a series of pipes to several individual houses and buildings, or blocks of buildings.

Exploration and Drilling

Many scientists, including geologists and hydrologists, chemical and civil engineers, and expert drilling technicians come together to collect and analyze information on the characteristics of a potential geothermal resource site. Sites are evaluated based on three primary criteria: heat content, fluid content, and permeability of the rock. Fortunately for geothermal explorers, hundreds of thousands of test holes have already been drilled all over the world by oil and gas companies. Researchers are able to use data from these deep wells to obtain information about the thermal energy in the area. These holes can also provide a way to use structural methods such as seismicity, gravity, and magnetic surveys to help determine the permeability beneath the surface. Electrical resistivity surveys can show how electricity flows through the rock and fluid beneath the surface and can help determine amount of available hydrothermal fluid. Once a site is identified as having geothermal potential, more exploratory wells are drilled and more data is collected and analyzed. Only after extensive checking and rechecking is a site recommended for development as one of the following energy conversion systems.

Energy Conversion:

The technology used to convert geothermal energy into forms usable for human consumption can be categorized into four groups. The first three: dry steam, flash steam, and binary cycle, typically use the hydrothermal fluid, pressurized brine, or EGS resources to generate electricity. The fourth type, direct use, requires only hydrothermal fluid, typically at lower temperatures, for direct use in heating buildings and other structures. The addition of a small-scale electric heat pump into the system allows the use of low temperature geothermal energy in residences and commercial buildings.

Dry Steam Power Plants

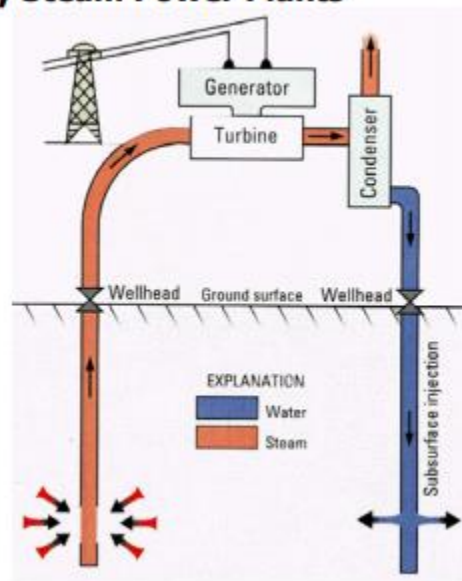

These were the first type of geothermal power plants to be built. The technology was first used at Lardarello, Italy, in 1904, and is still very effective for generating electricity. The plant uses steam that is accessed by drilling directly into the underground source. The steam is piped through a turbine and generator unit, and then condensed back into water and injected back into the subsurface reservoir. This helps to extend the life of the system. Steam technology is used today at The Geysers in northern California, the world's largest single source of geothermal power.

The emissions from this group of plants consist of excess steam and very small amounts of sulfur dioxide, hydrogen sulfide, and carbon dioxide. Because there is no combustion taking place, the levels of these gasses are much lower than emissions from fossil fuel fired power plants.

Flash Steam Power Plants

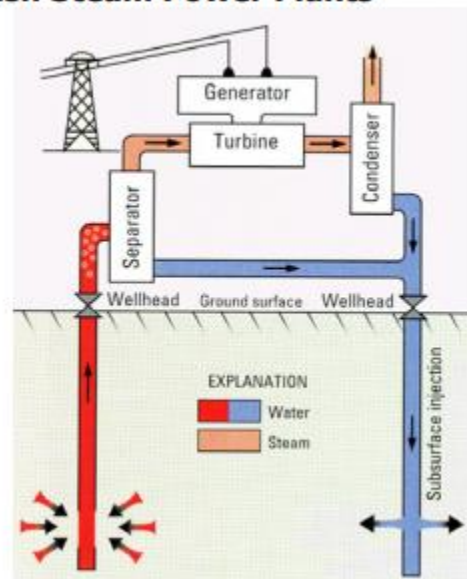

In these power plants, hydrothermal fluid at temperatures greater than 360°C is pushed to the surface by the high pressure in the subsurface reservoir. As this very hot fluid reaches the surface, it enters the separator where the pressure drops instantaneously and most of the liquid flashes into steam. The force generated by the steam is used to drive turbines and produce electricity. The fluid not flashed into steam leaves the separator and rejoins the water from the condenser. The fluid is then injected back into the Earth so that the process can be renewed over and over again. An example of an area using a flash steam operation is the CalEnergy Navy I flash geothermal power plant at the Coso geothermal field.

Binary Power Plants

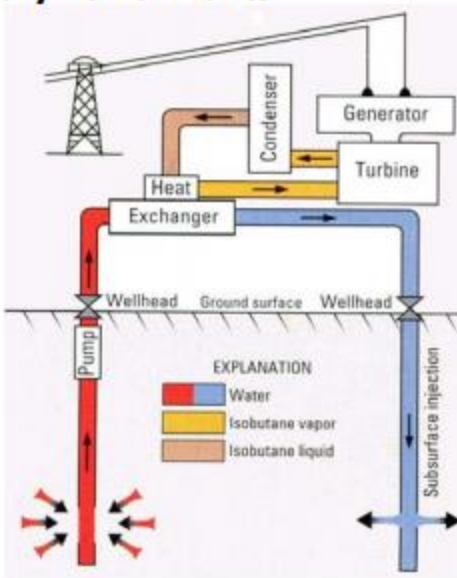

These are different from dry steam or flash steam power plants in that the hydrothermal fluid from the subsurface reservoir never comes into contact with the turbine/generator units. In this twostep process, hydrothermal fluid that is not quite hot enough to be used in a flash steam plant is fed into a heat exchanger. Here, heat is transferred from the hydrothermal fluid to a “working liquid” with a lower boiling point than water (usually isobutane or isopentane). The working liquid turns into an energized vapor much like the steam in the flash power plant and turns the turbine/generator unit, producing electricity. The hydrothermal fluid and the working liquid are both contained in “closed loops” and never come in contact with each another. The vapor from the working liquid is condensed and the hydrothermal fluid is returned to the earth. This cycle can be repeated as quickly as the Earth can reheat the fluid. An example of an area using a Binary Cycle power generation system is the Mammoth Pacific binary geothermal power plants at the Casa Diablo geothermal field. Because warm hydrothermal fluid is a more widespread resource than hot fluid or pressurized brines, binary systems have the potential to make a significant contribution to the overall production of geothermally generated electricity.

Direct use of hot water from geothermal resources can be used to provide heat for industrial processes, crop drying, or heating buildings. In this method, the hot fluid is pumped directly into a building’s hot water-based heating system, under sidewalks, or into pools. The city of Klamath Falls, Oregon, is located in an area of abundant near-surface hydrothermal fluid at the southern part of the Cascade Range. The Oregon Institute of Technology is actually heated by this direct-use system. Sidewalks in the area have tubes buried beneath them so as to prevent the buildup of snow and ice in the winter. Other examples of direct use geothermal resources exist across the entire western United States including the Capitol Mall in Boise, Idaho. Here, the city’s geothermal district heating system heats even the Idaho State Capitol Building. Geothermal water is also used by local industries in greenhouses, at fish farms, and by dairies.

Geothermal Heat Pumps

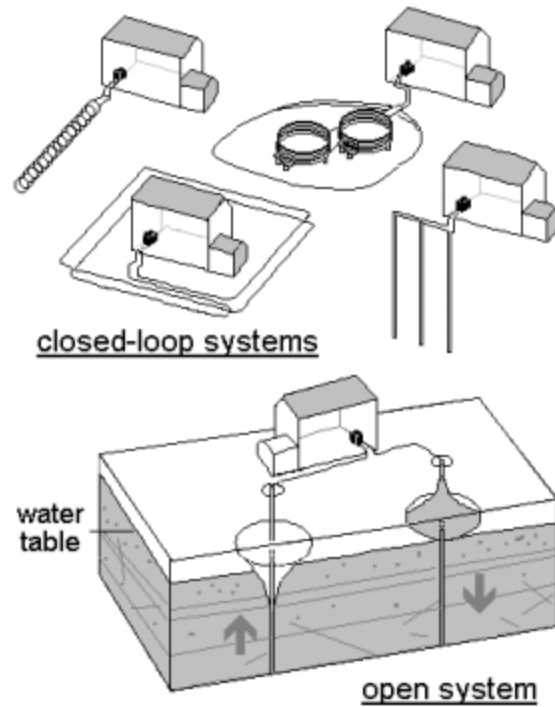

Also called ground source heat pumps, these systems can be used for heating and cooling buildings virtually anywhere, especially in regions where the geothermal potential is low. The internal heat energy of the Earth and the insulation from surface rocks and soils keep the subsurface at a near constant temperature of about 55 °F (13 °C). Wells are drilled to access the ground water at this temperature, and two types of systems can be employed. An open loop system simply pulls water up, runs it through the heat pump to add heat in the summer, and remove heat in the winter, and then recycles it back into the aquifer. A closed-loop system has the same function, except a loop of tubing is buried underground and filled with fluid, usually antifreeze. These systems work well in areas with moderate climates. Supplemental heating and cooling systems are required in more extreme areas. Some consumer resistance to geothermal heat pumps does exist due to the high initial purchase and installation cost. However, all geothermal heat pumps eventually provide savings on normal utility bills, some in as little as 3 or 4 years.

OCEAN ENERGY

The discussion of renewable energy sometimes focuses on what happens when the sun doesn't shine. What happens when the wind isn't strong enough to produce sufficient power? How can we store the energy we need? What happens when storage is not practical on a large scale, for instance, when you need to supply energy to a large energy grid? In areas of the country that have available coastline, but are limited in other renewable resources, they can use the oceans as their renewable resources. We are familiar with the large hydroelectric dams that dot our nation, creating large reservoirs and flooding millions of acres of land. By turning to the restless seas we can find a source of energy that is not affected by clouds and the scarcity of wind. By using ocean power, we can increase our need for power without having to deplete our existing non-renewable resources. Ocean power is divided into three categories: wave energy, tidal energy, and Ocean Thermal Energy Conversion (OTEC) Systems. Ocean Energy is estimated to be able to provide 2 to 3 million megawatts of power from our world's coastlines.

TIDAL ENERGY

The tides are cyclic variations in the level of seas and oceans. In effect, the tides represent the planetary manifestation of the potential and kinetic energy fluxes present in the Earth–Moon–Sun system. This results in some regions of the world possessing substantially higher local tidal variation than others.

Use of the tides there are two different means to harness tidal energy. The first is to exploit the cyclic rise and fall of the sea level using barrages and the second is to harness local tidal currents, analogous to wind power also called 'marine current turbine.'

Tidal barrage methods

Currently several places in the world are producing electricity from tides. The biggest tidal barrage power plant is located in La Rance, France. It has been operating since 1966, generates 240MW. Thanks to a road crossing of the estuary, the financial profitability is guaranteed. Other operational barrage sites are in Nova Scotia (20MW), near Murmansk, Russia (0.4MW) and the Eastern seaboard of China (3.2MW).

Principle of operation

An estuary or bay with a large natural tidal range is artificially enclosed with a barrier. Electrical energy is produced by allowing water to flow from one side of the barrage to the other. To generate electricity, tides go through low-head turbines. There are a variety of modes of operation. These can be broken down initially into single basin schemes or multiple basin schemes. The simplest of these are the single basin schemes.

Single basin barrage

It requires a single barrage across the estuary. That involves a combination of sluices which when open can allow water to flow relatively freely through the barrage and gated turbines. These gates can be opened to allow water to flow through the turbines to generate electricity.

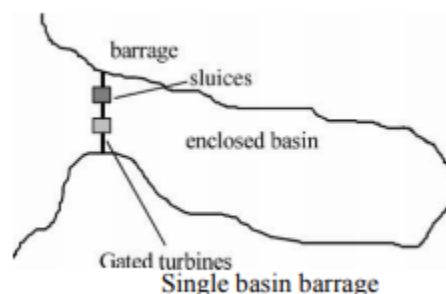

Ebb generation mode

Ebb generation depends on the height of the tides. At high tide, water is retained behind the barrage by the sluices. At low tides, water flows reverse out through the turbine.

Double basin systems

Double basin systems allow for storage (adjusting the power output to demand of consumers). The main basin behaves like the Ebb generation mode.

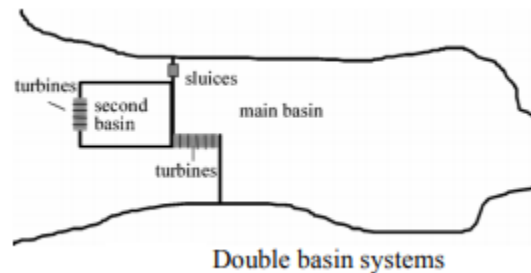

Marine current turbine

Tidal stream generators harness energy from currents generally in the same way as wind turbines. The higher density of water, 832 times the density of air, means that a single generator can provide significant power at low tidal flow velocities (compared with wind speed). Given that power varies with the density of medium and the cube of velocity, it is simple to see that water speeds of nearly one-tenth of the speed of wind provide the same power for the same size of turbine system. However, this limits the application in practice to places where the tide moves at speeds of at least 2 knots (1m/s), even close to neap tides (tide range is at a minimum). Ocean current resources are likely limited to the Florida Current, which flows between Florida and the Bahamas. Estimates of the energy present in the Florida Current date back to the mid-1970s, when the use of this resource for electricity generation was first proposed. While these early studies indicate an energy flux potential of as much as 25,000 MW through a single cross-sectional area, the amount of energy that could be extracted is uncertain, primarily because of concerns that reducing the energy in this portion of the Gulf Stream could have negative environmental consequences. Early modeling suggested that an array of turbines totaling 10,000 MW of capacity would not reduce the current's speed by more than what has been observed as its natural variation, and thus might be feasible (Lissaman and Radkey 1979; Charlier and Justus 1993). Further investigation is required to determine the magnitude of the technically available resource. Since tidal stream generators are an untested technology, no commercial scale production facilities are yet routinely supplying power; no standard technology has yet emerged. A large variety of designs are being experimented with, some very close to large scale deployment. Several prototypes have shown promise with many companies, but they have not operated commercially for extended periods to establish performances and rates of return on investments.

Two kinds of footings exist for the deep water installations. Conventionally the fixed systems are useful for shallow water sites, moored systems for deep water. The European Marine Energy Centre categorizes those under three headings.

Axial turbines

Axial turbines are close in concept to traditional windmills, operating under the sea and have the most prototypes currently operating. These include:

- Kvalsund, south of Hammerfest, Norway. Although still a prototype, a turbine with a reported capacity of 300 kW was connected to the grid on 13 Nov. 2003.
- A 300 kW period flow marine current propeller type turbine — Seaflow — was installed by Marine Current Turbines off the coast of Lynmouth, Devon, England, in 2003. The 11 meter diameter turbine generator was fitted to a steel pile which was driven into the seabed. As a prototype, it was connected to a dump load, not to the grid.
- Since April 2007, Verdant Power has

been running a prototype project in the East River between Queens and Roosevelt Island in New York City; it was the first major tidal-power project in the United States. The strong currents pose challenges to the design: the blades of the 2006 and 2007 prototypes broke off, and new reinforced turbines were installed in September 2008.

- Following the Seaflow trial, a full-size prototype, called SeaGen, was installed by Marine Current Turbines in Strangford Lough in Northern Ireland in April 2008. The turbine began to generate at full power of 1.2 MW in December, 2008, and was reported to have fed 150 kW into the grid for the first time on July 17, 2008. It is currently the only commercial scale device to have been installed anywhere in the world.
- Open Hydro, an Irish company exploiting the Open-Centre Turbine developed in the U.S., has a prototype being tested at the European Marine Energy Centre (EMEC), in Orkney, Scotland.
- A prototype semi-submerged floating tethered tidal turbine called Evopod has been tested since June 2008 in Strangford Lough, Northern Ireland at 1/10th scale. The company developing it is called Ocean Flow Energy Ltd, and they are based in the UK in Newcastle upon Tyne.

Vertical and horizontal axis cross-flow turbines

Vertical and horizontal axis cross-flow turbines can be deployed either vertically or horizontally.

- The Gorlov turbine is a variant of a helical design which is being commercially piloted on a large scale in South Korea.
- Neptune Renewable Energy has developed Proteus which uses a barrage of vertical axis crossflow turbines for use mainly in estuaries.
- In late April 2008, Ocean Renewable Power Company, LLC (ORPC) successfully completed the testing of its proprietary turbine-generator unit (TGU) prototype at ORPC's Cobscook Bay and Western Passage tidal sites near Eastport, Maine. The TGU is the core of the OCGen technology and utilizes advanced design crossflow (ADCF) turbines to drive a permanent magnet generator located between the turbines and mounted on the same shaft. ORPC has developed TGU designs that can be used for generating power from river, tidal and deep water ocean currents.

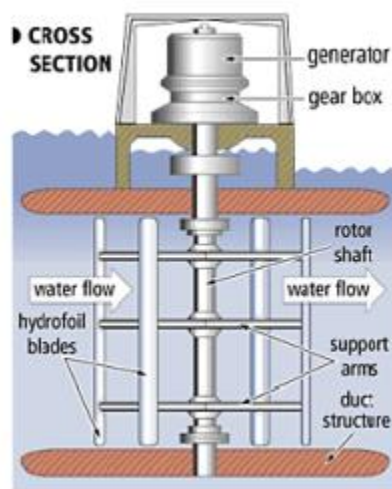

Schematic diagram of vertical axis turbine

Venturi effect designs

The Venturi effect uses a shroud to increase the flow rate through the turbine. These can be mounted horizontally or vertically.

- The Australian company Tidal Energy Pty Ltd undertook successful commercial trials of highly efficient shrouded tidal turbines on the Gold Coast, Queensland in 2002. Tidal Energy has commenced a rollout of their shrouded turbine for a 9 remote community in northern Australia where there are some of the fastest water flows ever recorded (11 m/s, 21 knots) – two small turbines provide 3.5 MW.

- Another larger 5 meter diameter turbine, capable of 800 kW in 4 m/s of flow, was planned for deployment as a tidal powered desalination showcase near Brisbane, Australia in October 2008.
- Another device, the Hydro Venturi, was tested in San Francisco Bay.
- Trials in the Strait of Messina, Italy, started in 2001 of the Kobold concept.

Commercial plans

The world's first commercial tidal stream generator — SeaGen — is in Strangford Lough. The strong wake demonstrates its power in the tidal current.

- RWE's npower announced that its partnership with Marine Current Turbines to build a tidal farm of SeaGen turbines off the coast of Anglesey in Wales.
- In November 2007, British company Lunar Energy announced that, in conjunction with E.ON, they would be building the world's first tidal energy farm off the coast of Pembrokeshire in Wales. It will be the world's first deep-sea tidalenergy farm and will provide electricity for 5,000 homes.
- Eight underwater turbines, each 25 meters long and 15 meters high, are installed on the sea bottom off St. David's peninsula. Construction started in the summer of 2008, and the proposed tidal energy turbines, described as "a wind farm under the sea", should be operational by 2010.
- British Columbia Tidal Energy Corp. plans to deploy at least three 1.2 MW turbines in the Campbell River or in the surrounding coastline of British Columbia, Canada by 2009.
- The organization Alderney Renewable Energy Ltd is planning to use tidal turbines to extract power from the notoriously strong tidal flows around Alderney UK in the Channel Islands. It is estimated that up to 3GW could be extracted. This would not only supply the island's needs but also allow a considerable surplus for export.
- Nova Scotia Power has selected OpenHydro's turbine for a tidal energy demonstration project in the Bay of Fundy, Nova Scotia, Canada and Alderney Renewable Energy Ltd for the supply of tidal turbines in the Channel Islands.

Potential sites

As with wind power, selection of location is critical for use with the tidal turbines. Tidal stream systems need to be located in areas with fast currents where natural flows are concentrated between obstructions, for example, at the entrances to bays and rivers, around rocky points, headlands, or between islands or other land masses. The following potential sites are under serious consideration:

- Pembrokeshire and River Severn in Wales.
- Kaipara Harbour and Cook Strait in New Zealand. - Bay of Fundy in Canada.
- East River in New York City and Piscataqua River in New Hampshire.
- Golden Gate in the San Francisco Bay.
- The Race of Alderney and The Swinge in the Channel Islands.

WAVE ENERGY:

Ocean waves represent a form of renewable energy created by wind currents passing over open water. Capturing the energy of ocean waves in offshore locations has been demonstrated as technically feasible. Also, basic research to develop improved designs of wave energy conversion (WEC) devices is being conducted in regions such as near the Oregon coast, which is a high wave energy resource (Rhinefrank 2005). Compared with other forms of offshore renewable energy, such as solar photovoltaic (PV), wind, or ocean current, wave energy is continuous but highly variable, although wave levels at a given location can be confidently predicted several days in advance.

As with many clean technologies, wave energy development began during the 70s, in response to that oil crisis. The problem with wave energy has been its low profitability, and so it has been difficult to reach commercial application. It is only since the mid-90s that these technologies have found a new lease from several small companies in Norway and the UK.

Wave energy represents a concentrated form of energy like solar energy. Solar power of 100W/m² corresponds to over 1000kW/m² of wave crest length. The power of waves depends on the wind; the most regular wind, and thus the most workable wave power, is generated between 30 and 60 degree of latitude. The largest potential is located in deep water. For example in UK, a wave loses two-third of its power when it reaches shallow water (at 20m). Topographic studies allow us to know the sea bed and thus to infer high potential areas; “hot spots” are concentrated on the shoreline. One other positive point is the congruence between production and consumption; the peak of production is observed during the winter as is the requirement for electricity.

Average annual wave power levels as kW/m of wave front are shown in Figure 4 below. The total annual average wave energy off the U.S. coastlines (including Alaska and Hawaii), calculated at a water depth of 60 m has been estimated (Bedard et al. 2005) at 2,100 Terawatt-hours (TWh) per year. Estimates of the worldwide economically recoverable wave energy resource are in the range of 140 to 750 TWh/yr for existing wave-capturing technologies that have become fully mature. With projected long-term technical improvements, this could be increased by a factor of 2 to 3. The fraction of the total wave power that is economically recoverable in U.S. offshore regions has not been estimated, but is significant even if only a small fraction of the 2,100 TWh/yr available is captured. (Currently, approximately 11,200 TWh/yr of primary energy is required to meet total U.S. electrical demand.) Wave energy conversion devices have the greatest potential for applications at islands such as Hawaii because of the combination of the relatively high ratio of available shoreline per unit energy requirement, availability of greater unit wave energies due to trade winds, and the relatively high costs of other local energy sources.

Ocean Thermal Energy Conversion:

Before beginning a description of ocean thermal energy conversion systems, a few features are needed to better understand the potential of this technology.

On an average day, 60 million square kilometers (23 million square miles) of tropical seas absorb an amount of solar radiation equal in heat content to about 250 billion barrels of oil. If less than one tenth of one percent of this stored solar energy could be converted into electric power, it would supply more than 20 times the total amount of electricity consumed in the United States on any given day.

Ocean thermal energy conversion (OTEC) is a method which consists of extracting energy from the difference in temperature between shallow and deep waters by way of a heat engine. The biggest difference in temperature (around 20 degrees Celsius, generally located near the equator or tropics), between a heat and cold source provides the greatest amount of potential energy. Thus, the main technical challenge is to generate the most amount of power from a small temperature ratio.

Compared with technologies such as wave energy, the energy available from OTEC is one or two orders of magnitude higher. But the thermal efficiency is very low; the theoretical maximum efficiency is 6 or 7%. Furthermore, the extraction of energy is difficult and thus expensive (pumping material).

This technology, if it could be economically competitive with conventional power technologies, could output gigawatts of electrical power. Electrolysis could produce hydrogen to enhance energy output from the process of OTEC.

Types of OTEC technology

Several options exist for OTEC technology depending of the location and the cycle used. Plants may be based on land, ocean shelf or floating facilities. The first two have the most advantages. Three kinds of cycles are used: the open cycle, the closed cycle and the hybrid cycle.

The main concept is the same for all systems. There is a heat engine placed between a high temperature and low temperature reservoir. As in a steam turbine, the engine converts heat energy

into kinetic energy. To operate, the cold sea water is either pumped directly (can be more than one kilometer) or desalinated near the sea bed to then float up through a pipe to the surface.

Closed-cycle

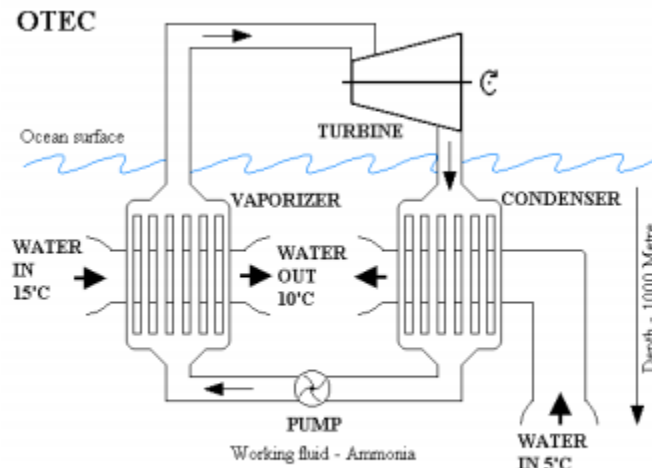

OTEC closed-cycle block diagram

This cycle uses a working fluid (with a low boiling point) which is cooled down and heated up in a full cycle. The warm water located at the surface is injected into a heat exchanger; the working fluid gets the heat to change its state, and is vaporized. The vapor is directed through the turbine and generator where the electricity is produced. Then the vapor is condensed by the deep cold water. The liquid goes back to the heat exchanger and so on. India has built a closed-cycle, floating plant of 1 MW rated power.

Open-cycle

The open-cycle process does not use an intermediate fluid like the closed-cycle but directly uses the sea water. It uses the warm surface in tropical seas.

The warm water is placed in a low-pressure container which carries out the evaporation. Like in others cycles, the steam is driven into the turbine attached to a generator. The second effect is the production of desalinated water (fresh water) through evaporation. The steam is condensed into liquid by the deep cold water. Contrary to the first cycle, the water is captured because it is now clean drinking water.

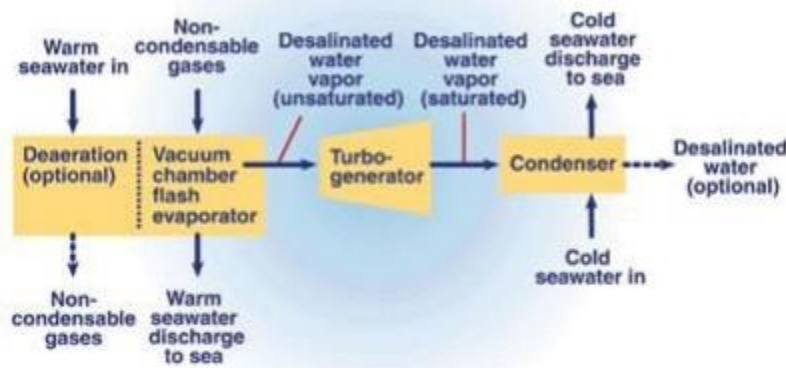

OTEC open-cycle line diagram

Hybrid cycle

The last cycle proposes to combine both open and closed cycles. The warm water is vaporized in a vacuum chamber. The steam transforms working liquid into vapor (heat exchanger) which is directed in a turbine. As in the open-cycle the condensed water provides fresh water.

Applications for OTEC

As explained previously, the main goal of this system is to output electric power and, secondly, desalinated water (2-megawatt electric plant could produce about 4300 cubic meters of desalinated water each day) for some cycles. But OTEC technology offers others possibilities, like support for deep water mariculture (deep waters rich in nutrients) and air conditioning. It also can be used to produce ammonia (the working fluid), hydrogen, aluminum, methanol and others chemicals.

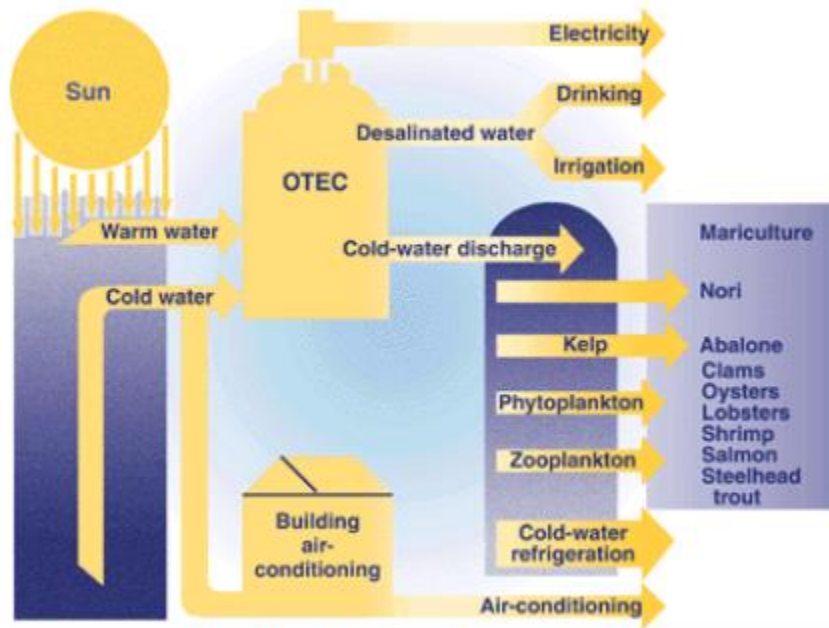

Block diagram of all applications from OTEC technology

MODULE-V

Direct Energy Conversion:

Energy conversion devices convert between electrical, magnetic, kinetic, potential, optical, chemical, nuclear, and other forms of energy. Energy conversion processes occur naturally. For example, energy is converted from optical electromagnetic radiation to heat when sunlight warms a house, and energy is converted from potential energy to kinetic energy when a leaf falls from a tree. Alternatively, energy conversion devices are designed and manufactured by a wide range of scientists and engineers. These energy conversion devices range from tiny integrated circuit components such as thermocouples which are used to sense temperature by converting microwatts of power from thermal energy to electricity to enormous coal power plants which convert gigawatts of energy stored in the chemical bonds of coal into electricity.

A direct energy conversion device converts one form of energy to another through a single process. For example, a solar cell is a direct energy conversion device that converts optical electromagnetic radiation to electricity. While some of the sunlight that falls on a solar cell may heat it up instead, that effect is not fundamental to the solar cell operation. Alternatively, indirect energy conversion devices involve a series of direct energy conversion processes. For example, some solar power plants involve converting optical electromagnetic radiation to electricity by heating a fluid so that it evaporates. The evaporation and expansion of the gas spin a rotor of a turbine. The energy from the mechanical motion of the rotor is converted to a time varying magnetic field which is then converted to an alternating electrical current in the coils of the generator.

Process	Forms of Energy	Example Devices	Discussed in Section
Piezoelectricity	Electricity ↕ Mechanical Energy	Piezoelectric Vibration Sensor, Electret Microphone	2.3
Pyroelectricity	Electricity ↕ Heat	Pyroelectric Infrared Detector	3
Electro-optic Effect	Optical Electro-magnetic Energy ↕ Material Polarization	Controllable Optics, Liquid Crystal Displays	3.3
Electromagnetic Transmission and Reception	Electricity ↕ Electromagnetic Energy	Antenna	4
Hall Effect	Electricity ↕ Magnetic Energy	Hall Effect Device	5
Magnetohydrodynamic Effect	Electricity ↕ Magnetic Energy	Magnetohydrodynamic Device	5.3
Absorption	Optical Electro-magnetic Energy ↓ Electricity	Solar cell, Semiconductor Optical Photodetector	6

Process	Forms of Energy	Example Devices	Discussed in Section
Spontaneous Emission	Electricity ↓ Optical Electro-magnetic Energy	Lamp, LED	7.3
Stimulated Emission	Electricity ↓ Optical Electro-magnetic Energy	Laser, Optical Amplifier	7.4
Thermoelectric Effects (Incl. Seebeck, Peltier and Thomson)	Electricity ↑ Heat	Thermoelectric cooler, Peltier device, Thermocouple	8.8
(Battery or Fuel Cell) Discharging	Chemical Energy ↓ Electricity	Battery, Fuel Cell	9
(Battery or Fuel Cell) Charging	Electricity ↓ Chemical Energy	Battery, Fuel Cell	9
Thermionic Emission	Heat ↓ Electricity	Thermionic Device	10.2
Electrohydrodynamic Effect	Electricity ↑ Fluid flow	Microfluidic Pump, Valve	10.6

Variety of energy conversion processes.

Device	Similar to Component	Forms of Energy	Discussed Section
Piezoelectric Device	Capacitor	Electricity ↑ Mechanical Energy	2.3
Pyroelectric Device	Capacitor	Electricity ↑ Heat	3
Electro-optic Device	Capacitor	Optical Energy ↑ Material Polarization	3.3
Antenna	Inductor	Electricity ↑ Electromagnetic	4
Hall Effect Device	Inductor	Electricity ↑ Magnetic Energy	5
Magnetohydrodynamic Device	Inductor	Electricity ↑ Magnetic Energy	5.3
Solar Cell	Diode	Optical Energy ↓ Electricity	6
LED, Laser	Diode	Electricity ↓ Optical Energy	7
Thermoelectric Device	Diode	Electricity ↑ Heat	8.8
Geiger Counter	Diode	Radiation ↓ Electricity	10.3
Resistance Temp. Detector	Resistor	Heat ↓ Electricity	10.5
Potentiometer	Resistor	Electricity ↓ Heat	10.5
Strain Gauge	Resistor	Mechanical Energy ↓ Electricity	10.5

Variety of energy conversion devices.

Carnot Cycle

1 to 2: Reversible isothermal expansion of the gas at the "hot" temperature, T_H (isothermal heat addition or absorption). During this step (A to B on T-S diagram, 1 to 2 P-V diagram) the expanding gas makes the piston work on the surroundings. The gas expansion is propelled by absorption of quantity Q_1 of heat from the high temperature reservoir.

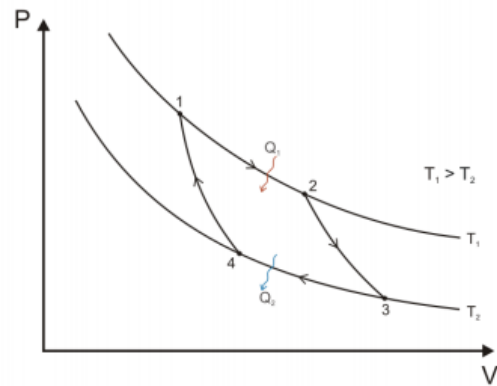
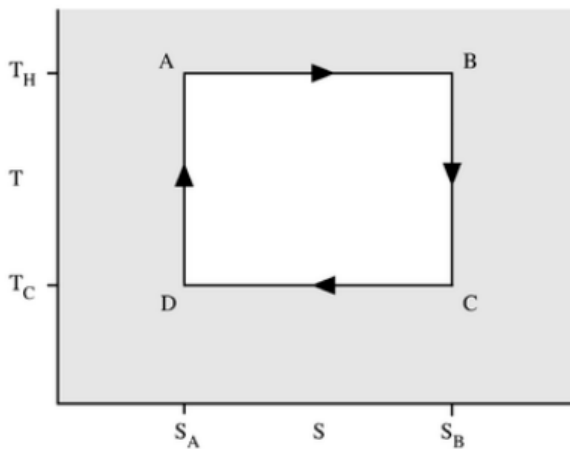

2 to 3: Reversible adiabatic expansion of the gas. For this step (B to C on T-S diagram, 2 to 3 on P-V diagram) the piston and cylinder are assumed to be thermally insulated, thus they neither gain nor lose heat. The gas continues to expand, working on the surroundings. The gas expansion causes it to cool to the "cold" temperature, T_C .

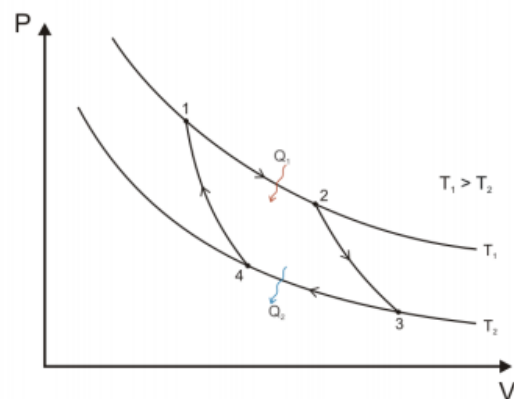
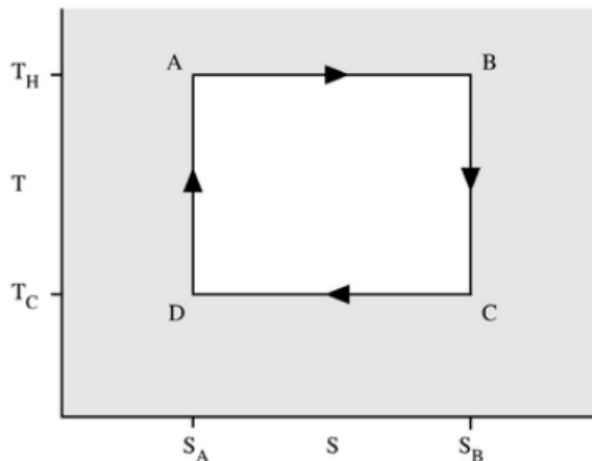

3 to 4: Reversible isothermal compression of the gas at the "cold" temperature, T_C . (isothermal heat rejection) (C to D on T-S diagram, 3 to 4 on P-V diagram). Now the surroundings do work on the gas, causing quantity Q_2 of heat to flow out of the gas to the low temperature reservoir.

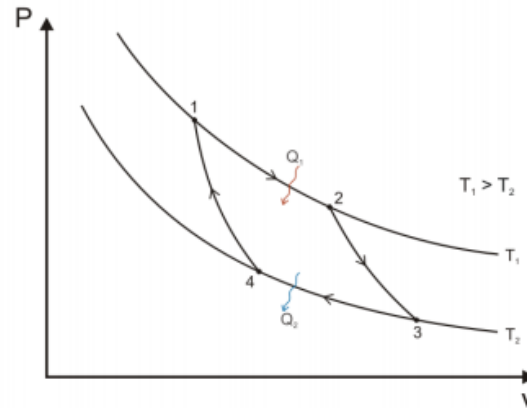
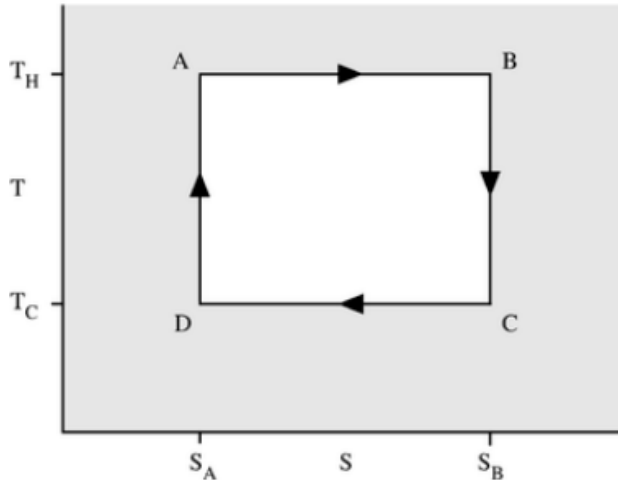

4 to 1: Reversible adiabatic compression of the. (D to A on T-S diagram, 4 to 1 on P-V diagram) Once again the piston and cylinder are assumed to be thermally insulated. During this step, the surroundings do work on the gas, compressing it and causing the temperature to rise to T_H . At this point the gas is in the same state as at the start of step 1.

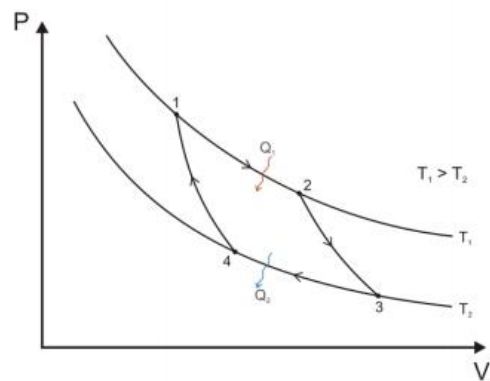
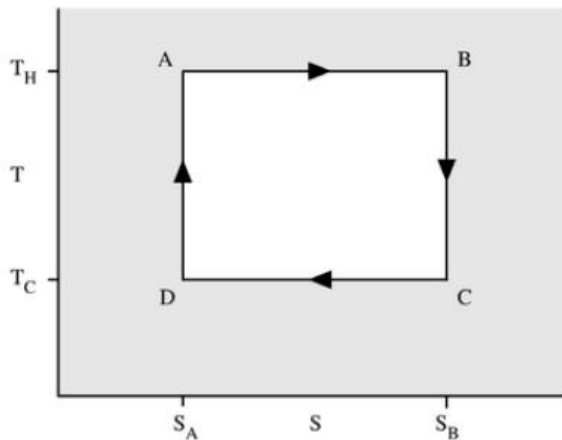

seebeck, peltier and joul Thomson effects:

The **thermoelectric effect** is the direct conversion of temperature differences to electric voltage and vice versa via a thermocouple. Thermoelectric devices create a voltage when there is a different temperature on each side. Conversely, when a voltage is applied to it, heat is transferred from one side to the other, creating a temperature difference. At the atomic scale, an applied temperature gradient causes charge carriers in the material to diffuse from the hot side to the cold side.

The **Seebeck effect** is the buildup of an electric potential across a temperature gradient. A thermocouple measures the difference in potential across a hot and cold end for two dissimilar materials. This potential difference is proportional to the temperature difference between the hot and cold ends. First discovered in 1794 by Italian scientist Alessandro Volta it is named after the Baltic German physicist Thomas Johann Seebeck, who in 1821 independently rediscovered it. It was observed that a compass needle would be deflected by a closed loop formed by two different metals joined in two places, with an applied temperature difference between the joints. This was because the electron energy levels shifted differently in the different metals, creating a potential difference between the junctions which in turn created an electrical current through the wires, and therefore a magnetic field around the wires. Seebeck did not recognize that an electric current was involved, so he called the phenomenon "thermomagnetic effect".

Peltier Effect:

When an electric current is passed through a circuit of a thermocouple, heat is evolved at one junction and absorbed at the other junction. This is known as Peltier Effect. The **Peltier effect** is the presence of heating or cooling at an electrified junction of two different conductors and is named after French physicist Jean Charles Athanase Peltier, who discovered it in 1834. When a current is made to flow through a junction between two conductors, A and B, heat may be generated or removed at the junction. The Peltier heat generated at the junction per unit time is

$$\dot{Q} = (\Pi_A - \Pi_B)I,$$

where Π_A and Π_B are the Peltier coefficients of conductors A and B, and I is the electric current (from A to B). The total heat generated is not determined by the Peltier effect alone, as it may also be influenced by Joule heating and thermal-gradient effects

Thomson Effect:

In different materials, the Seebeck coefficient is not constant in temperature, and so a spatial gradient in temperature can result in a gradient in the Seebeck coefficient. If a current is driven through this gradient, then a continuous version of the Peltier effect will occur. This **Thomson effect** was predicted and later observed in 1851 by [Lord Kelvin](#) (William Thomson). It describes the heating or cooling of a current-carrying conductor with a temperature gradient.

If a current density J is passed through a homogeneous conductor, the Thomson effect predicts a heat production rate per unit volume.

$$\dot{q} = -\mathcal{K}J \cdot \nabla T,$$

where ∇T is the temperature gradient, and \mathcal{K} is the Thomson coefficient. The Thomson coefficient is related to the Seebeck coefficient as $\mathcal{K} = T \frac{dS}{dT}$

Magneto hydrodynamic generator:

A **magneto hydrodynamic generator (MHD generator)** is a magneto hydrodynamic converter that utilizes a Brayton cycle to transform thermal energy and kinetic energy directly into electricity. MHD generators are different from traditional electric generators in that they operate without moving parts (e.g. no turbine) to limit the upper temperature. They therefore have the highest known theoretical thermodynamic efficiency of any electrical generation method. MHD has been extensively developed as a topping cycle to increase the efficiency of electric generation, especially when burning coal or natural gas. The hot exhaust gas from an MHD generator can heat the boilers of a steam power plant, increasing overall efficiency.

An MHD generator, like a conventional generator, relies on moving a conductor through a magnetic field to generate electric current. The MHD generator uses hot conductive ionized gas

(a plasma) as the moving conductor. The mechanical dynamo, in contrast, uses the motion of mechanical devices to accomplish this.

Practical MHD generators have been developed for fossil fuels, but these were overtaken by less expensive combined cycles in which the exhaust of a gas turbine or molten carbonate fuel cell heats steam to power a steam turbine.

MHD dynamos are the complement of MHD accelerators, which have been applied to pump liquid metals, seawater and plasmas.

Natural MHD dynamos are an active area of research in plasma physics and are of great interest to the geophysics and astrophysics communities, since the magnetic fields of the earth and sun are produced by these natural dynamos.

Electro Gas Dynamic Generator

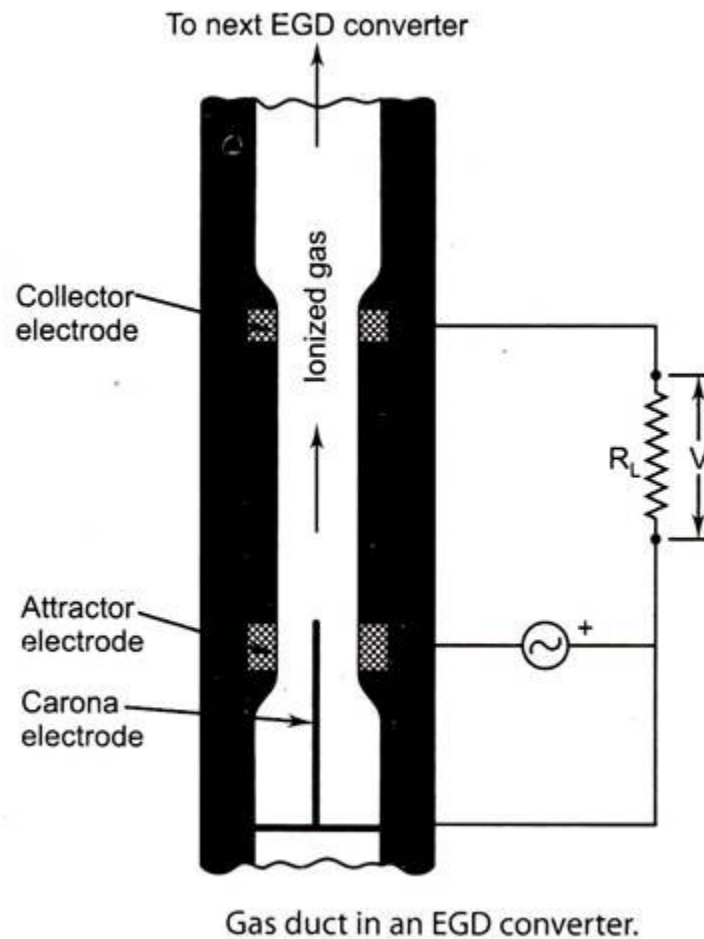

'Carona electrode' at the entrance of the duct generates electrons. This ionized gas particles are carried down the duct with the neutral atoms and the ionized particles are neutralized by the 'collector electrode', at the end of the insulated duct. The working fluid in these systems are commonly, either combustion gases produced by burning of fuel at high pressures, or it is a pressurized reactor gas coolant.

The maximum power output from EGD is about 10 to 30 W per channel. Hence, several thousand channels are connected in series and parallel. The voltage produced is very high, of the order of 1,00,000 to 2,00,000 V. Thus, it needs very good high voltage insulators (Beryllium Oxide is generally used).

The EGD generator uses the potential energy of a high pressure gas to carry electrons from a low potential electrode to a high potential electrode, thereby doing work against an electric field. EGD can produce a high efficiency equal to MHD-steam combination

Advantages of EGD over MHD Systems:

- EGD systems operate at relatively low temperatures.
- No need for injection and recovery of seed material.
- This system is self-contained since it does not need a steam generator.
- Energy can be extracted till the gases reach almost the stack temperature.

Fuel Cell

A **fuel cell** is an electrochemical cell that converts the chemical energy of a fuel (often hydrogen) and an oxidizing agent (often oxygen^[1]) into electricity through a pair of redox reactions.^[2] Fuel cells are different from most batteries in requiring a continuous source of fuel and oxygen (usually from air) to sustain the chemical reaction, whereas in a battery the chemical energy usually comes from metals and their ions or oxides^[3] that are commonly already present in the battery, except in flow batteries. Fuel cells can produce electricity continuously for as long as fuel and oxygen are supplied.

The first fuel cells were invented by Sir William Grove in 1838. The first commercial use of fuel cells came more than a century later following the invention of the hydrogen–oxygen fuel cell by Francis Thomas Bacon in 1932. The alkaline fuel cell, also known as the Bacon fuel cell after its inventor, has been used in NASA space programs since the mid-1960s to generate power for satellites and space capsules. Since then, fuel cells have been used in many other applications. Fuel cells are used for primary and backup power for commercial, industrial and residential buildings and in remote or inaccessible areas. They are also used to power fuel cell vehicles, including forklifts, automobiles, buses, boats, motorcycles and submarines.

There are many types of fuel cells, but they all consist of an anode, a cathode, and an electrolyte that allows ions, often positively charged hydrogen ions (protons), to move between the two sides of the fuel cell. At the anode a catalyst causes the fuel to undergo oxidation reactions that generate ions (often positively charged hydrogen ions) and electrons. The ions move from the anode to the cathode through the electrolyte. At the same time, electrons flow from the anode to the cathode through an external circuit, producing direct current electricity. At the cathode, another catalyst causes ions, electrons, and oxygen to react, forming water and possibly other products. Fuel cells are classified by the type of electrolyte they use and by the difference in startup time ranging from 1 second for proton exchange membrane fuel cells (PEM fuel cells, or PEMFC) to 10 minutes for solid oxide fuel cells (SOFC). A related technology is flow batteries, in which the fuel can be regenerated by recharging. Individual fuel cells produce relatively small electrical potentials, about 0.7 volts, so cells are "stacked", or placed in series, to create sufficient voltage to meet an application's requirements.^[4] In addition to electricity, fuel cells produce water, heat and, depending on the fuel source, very small amounts of nitrogen dioxide and other emissions. The energy efficiency of a fuel cell is generally between 40–60%; however, if waste heat is captured in a cogeneration scheme, efficiencies of up to 85% can be obtained.

The fuel cell market is growing, and in 2013 Pike Research estimated that the stationary fuel cell market will reach 50 GW by 2020.

The Base Structure of Fuel Cells

A fuel cell is an electrochemical device which converts the chemical energy of a fuel and an oxidant directly into electrical energy. The basic physical structure of a single cell consists of an electrolyte layer in contact with a porous anode and cathode on either side.

In a typical fuel cell, gaseous fuels are fed continuously to the anode (negative electrode) and an oxidant (i.e., oxygen from air) is fed continuously to the cathode (positive electrode) compartment; the electrochemical reactions take place at the electrodes to produce an electric current

In the case of a fuel cell with an acid electrolyte the electrochemical reactions are:

anodic reaction: $\text{H}_2 \rightarrow 2\text{H}^+ + 2\text{e}^-$

cathodic reaction: $\frac{1}{2}\text{O}_2 + 2\text{H}^+ + 2\text{e}^- \rightarrow \text{H}_2\text{O}$

overall reaction: $\text{H}_2 + \frac{1}{2}\text{O}_2 \rightarrow \text{H}_2\text{O} + \text{heat}$ (exothermic reaction, $\Delta H = -286 \text{ kJ mol}^{-1}$)

A fuel cell, although having components and characteristics similar to those of a typical battery, differs in several respects. The battery is an energy storage device and the available energy is determined by the chemical reactant stored within the battery itself. The battery will cease to produce electrical energy when the chemical reactants are consumed (i.e., battery discharged). In a secondary battery (fuel cell), the reactants are continuously supplied from an external source.

The fuel cell, on the other hand, is an energy conversion device that theoretically has the capability of producing electrical energy for as long as the fuel and oxidant are supplied to the electrodes.

Types Fuel cells:

Fuel cells come in many varieties; however, they all work in the same general manner. They are made up of three adjacent segments: the anode, the electrolyte, and the cathode. Two chemical reactions occur at the interfaces of the three different segments. The net result of the two reactions is that fuel is consumed, water or carbon dioxide is created, and an electric current is created, which can be used to power electrical devices, normally referred to as the load.

At the anode a catalyst oxidizes the fuel, usually hydrogen, turning the fuel into a positively charged ion and a negatively charged electron. The electrolyte is a substance specifically designed so ions can pass through it, but the electrons cannot. The freed electrons travel through a wire creating the electric current. The ions travel through the electrolyte to the cathode. Once reaching the cathode, the ions are reunited with the electrons and the two react with a third chemical, usually oxygen, to create water or carbon dioxide.

Design features in a fuel cell include:

- The electrolyte substance, which usually defines the *type* of fuel cell, and can be made from a number of substances like potassium hydroxide, salt carbonates, and phosphoric acid.
- The fuel that is used. The most common fuel is hydrogen.
- The anode catalyst, usually fine platinum powder, breaks down the fuel into electrons and ions.
- The cathode catalyst, often nickel, converts ions into waste chemicals, with water being the most common type of waste.
- Gas diffusion layers that are designed to resist oxidization.

The Advantages and Disadvantages of Fuel Cells

- Higher volumetric and gravimetric efficiency
- Low chemical, acoustic, and thermal emissions
- Modularity and siting flexibility
- Low maintenance
- Fuel flexibility (depending on type of fuel cell)
- No production of pollutants